

CANTONI
MOTOR

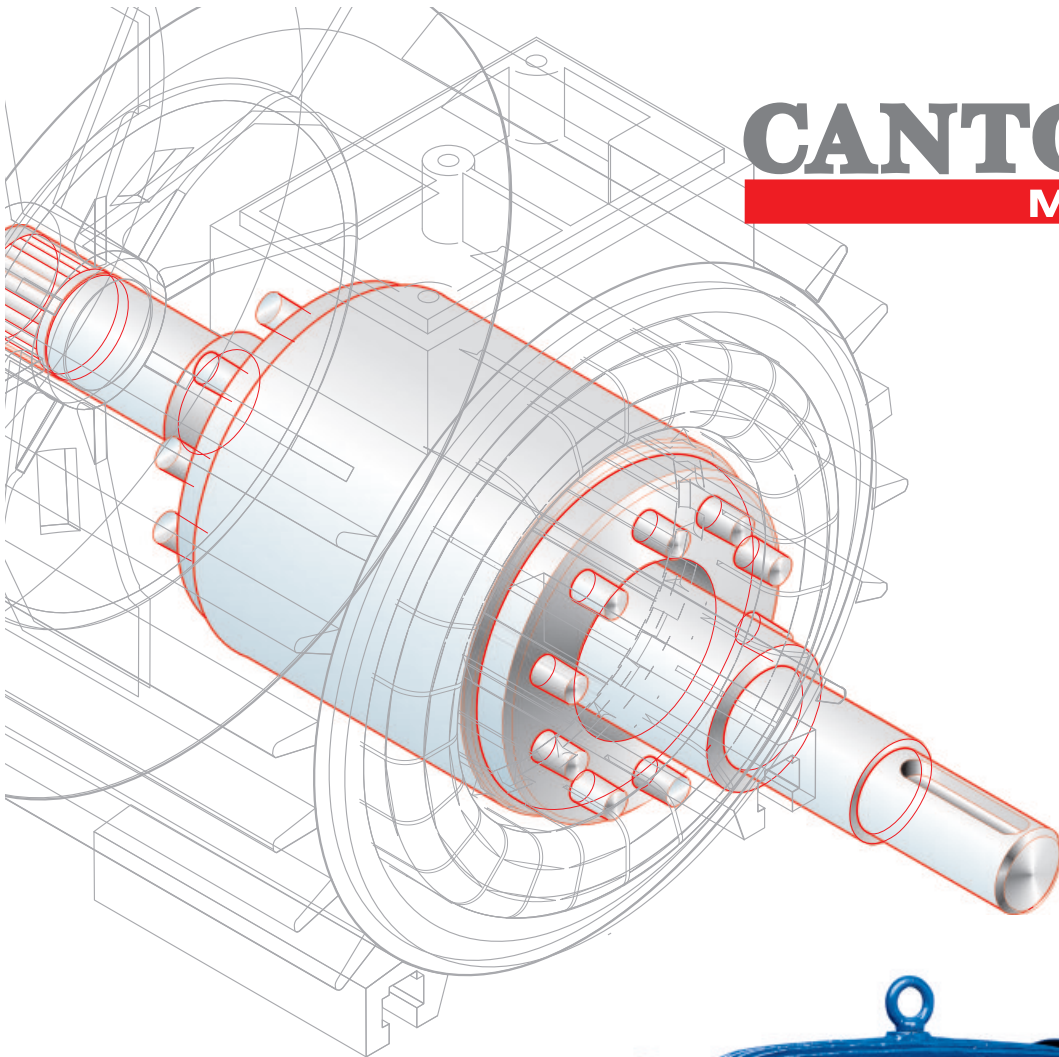

**General
Purpose
3-Phase
Induction
Motors**

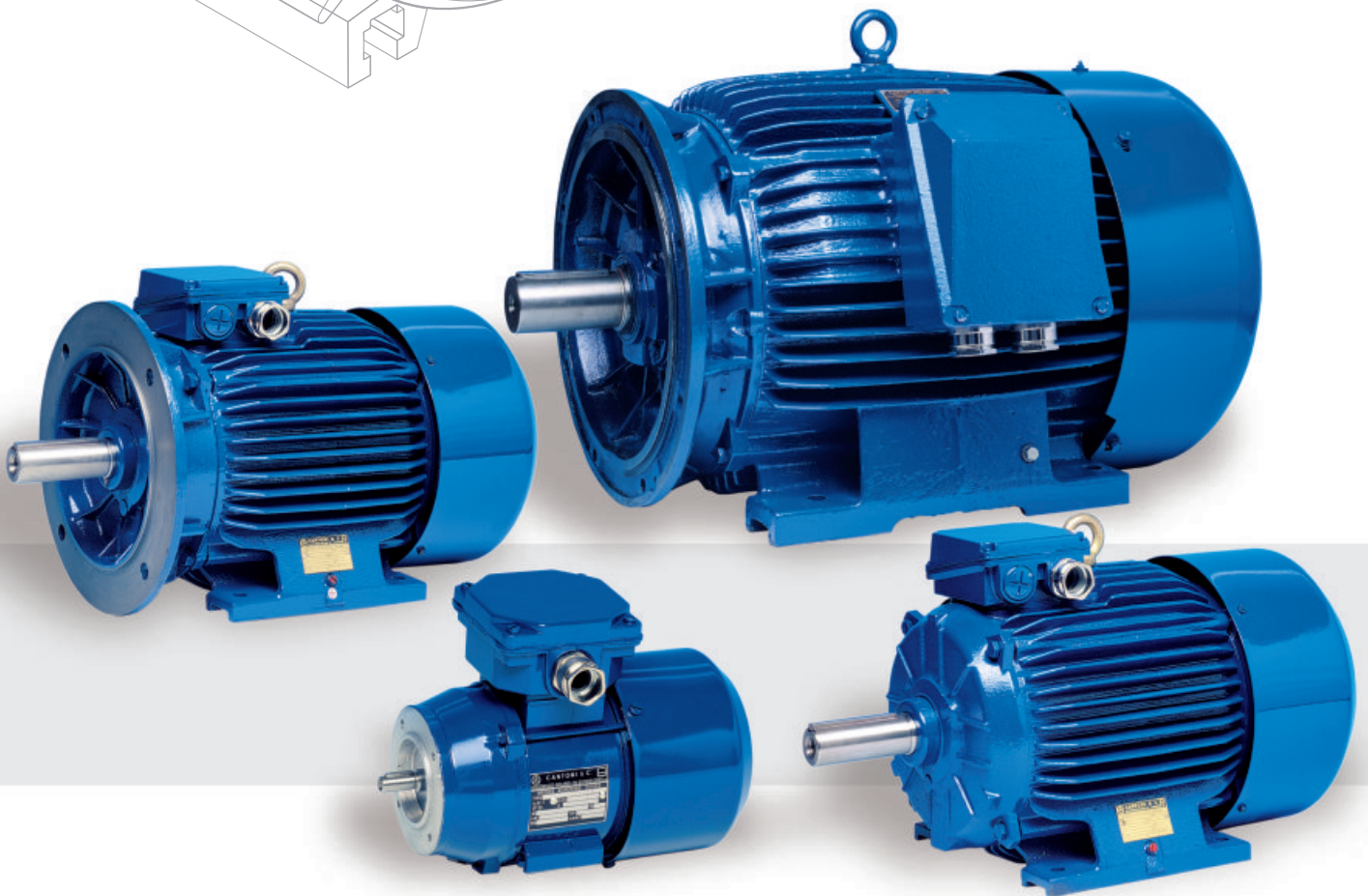

Product Catalogue

Certificates

Cantoni Motor SA
ISO 9001
KEMA
Since September 30, 1999
Number 99515

Besel SA
ISO 9001
DQS
Since July 21, 1995
Number 002887Q1

Indukta SA
ISO 9001
KEMA
Since April 1, 1993
ISO 14001
KEMA
Since July 1, 2001
Number 2019916

Celma SA
ISO 9001
Germanischer Lloyd
since June 16, 1995
Number QS-243 HH
ISO 14001
Germanischer Lloyd
Since November 15, 1999
Number EM-1835 HH

Emit SA
ISO 9001
Polski Rejestr Statków
Since January 23, 1997
Number NC-034/00

KEMA

CERTIFICATE

Number: 99515

The management system of:
**Cantoni Motor S.A.
Warsaw
Poland**

including the implementation meets the requirements of the standard:
ISO 9001:2000

Scope:
Export sale of electric motors, co-ordination of the procurement of materials for the production of electric motors, accounting reporting for the companies of the Group.

The file that forms the basis of this certificate:
99515-QUA, 2040419-QUA

This certificate is valid until: April 1, 2009

Issued for the first time: September 30, 1999

KEMA Quality B.V.
Piotr Dabrowski
Certification Manager

ACCREDITED BY
THE DUTCH COUNCIL
FOR ACCREDITATION

Integral publication of this certificate and adjoining reports is allowed.

**CERTYFIKAT
CERTIFICATE**

Przyznany organizacji:
Issued for:
**Zakład Maszyn Elektrycznych "EMIT" S.A.
ul. Narutowicza 72
99-320 Żychlin**

Biurowy Rejestr Statków S.A. zawiadacza, że System Zarządzania Jakością wyżej wymienionej organizacji został oceniony i stwierdzono zgodność z wymaganiami:
Certification Bureau of Polish Register of Ships S.A. certifies that the Quality Management System of the above organization has been assessed and found to be in accordance with the requirements of:
ISO 9001:2000

Zakres certyfikacji:
PROJEKTOWANIE I PRODUKCJA:
- SILNIKÓW INDUKCYJNYCH TRÓJFAZOWYCH
- GENERATORÓW SYNCHRONICZNYCH
- MASZYN PRĄDU STAŁEGO
- ZESTAWÓW PRAKTYCZNYCH
- CZĘŚCI I PODZESTAWÓW DO MASZYN ELEKTRYCZNYCH
- KONSTRUKCJE SPRAWYJĄCYCH
ORAZ REMONTY MASZYN ELEKTRYCZNYCH

Scope of certification:
DESIGN AND MANUFACTURE OF:
- THREE-PHASE INDUCTION MOTORS
- SYNCHRONOUS GENERATORS
- POWER GENERATING SETS
- PARTS AND SUBASSEMBLIES FOR ELECTRIC MACHINES
- WELDED STRUCTURES
AND REPAIRS OF ELECTRIC MACHINES

Pierwsze wydanie Certyfikatu:
Certificate first issue: **23.01.1997**

Certyfikat jest ważny do:
The Certificate is valid until: **22.01.2009**

Nr Certyfikatu: **NC-034**
Certificate No.:

Gdańsk, 26.01.2006

AC 014
GMS

Jan Jankowski
Bogdan Przybylski

KEMA

CERTIFICATE

Number: 2019916

The management system of:
**Fabryka Maszyn Elektrycznych INDUKTA S.A.
Bielsko - Biala
Poland**

including the implementation meets the requirements of the standard:
**ISO 9001:2000
ISO 14001:2004**

Scope:
Development, production, packing and dispatch of electrical three-phase motors with an output up to and including 30kW.

The file that forms the basis of this certificate:
2040373-QUA, 2040374-QUA

This certificate is valid until: November 1, 2008

for the first time: April 1, 1993 - ISO 9001
July 1, 2001 - ISO 14001

Quality B.V.
G. Nabours
Director of the International
In Assessment and CE
Certification of this certificate and

DQS

CERTIFICATE

**DQS GmbH
Deutsche Gesellschaft zur Zertifizierung von Managementsystemen**

hereby certifies that the company

**Fabryka Silników Elektrycznych
„BESEL” S.A.
ul. Elektryczna 8
48-300 Brzoz
Poland**

for the scope

design, production, sale and service of single-phase and three-phase asynchronous, electric motors of low power

has implemented and maintains a
Quality Management System.

An audit, documented in a report, has verified that this quality management system fulfills the requirements of the following standard:

DIN EN ISO 9001 : 2000
December 2000 edition

This certificate is valid until: **2008-07-09**

Certificate Registration No.: **003957 GM**

Issued on Main: **2008-07-09**

MANAGING DIRECTORS
Dir. Ing. G. Heesdel

Certification Body: DQS GmbH, 82423 Friedland am Meer, August-Sandweg 21, Germany (Tel: +49 49 95 42 70) Office: DQS Polska Sp. z o.o., ul. Marynarska 11, 82-474 Włocławek - Poland (Tel: +48 25 627 06 10)

CERTIFICATE

The Germanischer Lloyd Certification GmbH, 20469 Hamburg, herewith certifies that the company

**Maszyny Elektryczne CELMA S.A.
ul. 3 Maja 15, PL-43-430 Cieszyń**

with the subsidiary

**Odlewnia Żeliwa Cieszyń Sp. z o.o.
ul. 3 Maja 15, PL-43-430 Cieszyń**

has established and maintains an Environmental Management System relevant for
**Design, production and repair of electric machines,
Iron castings.**

Germanischer Lloyd Certification GmbH has audited the company. Evidence was provided that the Environmental Management System fulfills the requirements of the following standard:

ISO 14001:2004

The validity of this certificate is subject to the company applying and maintaining its Environmental Management System in accordance with the standard indicated. This will be monitored by Germanischer Lloyd Certification GmbH.

This certificate is valid until: December 11, 2008
Hamburg, December 11, 2005

Certificate No. **EM-1835 HH**

Germanischer Lloyd
Certification

CERTIFICATE

The Germanischer Lloyd Certification GmbH, 20469 Hamburg, herewith certifies that the company

**Maszyny Elektryczne CELMA S.A.
ul. 3 Maja 15, PL-43-430 Cieszyń**

with the subsidiary

**Odlewnia Żeliwa Cieszyń Sp. z o.o.
ul. 3 Maja 15, PL-43-430 Cieszyń**

has established and maintains a Quality Management System relevant for
**Design, production and repair of electric machines,
Iron castings.**

Germanischer Lloyd Certification GmbH has audited the company. Evidence was provided that the Quality Management System fulfills the requirements of the following standard:

DIN EN ISO 9001:2000

The validity of this certificate is subject to the company applying and maintaining its Quality Management System in accordance with the standard indicated. This will be monitored by Germanischer Lloyd Certification GmbH.

This certificate is valid until: December 23, 2008
Hamburg, December 23, 2005

Certificate No. **QS-243 HH**

Germanischer Lloyd
Certification

Cantoni[®]

GROUP

Cantoni Motor S.A.
M. Grażyńskiego 22, 43-300 Bielsko-Biała, Poland
tel.: +48 33 813 87 00
fax: +48 33 813 87 01
motor@cantonigroup.com
www.cantonimotor.com

since 1950



since 1878



since 1954



since 1920



since 1921



Contents

General information	pages 5-12
<hr/>	
<i>Description of the catalogue version</i>	
<i>Description of the customised version</i>	
<i>Ratings-tolerances</i>	
<i>Standards and equivalents</i>	
<i>Efficiency</i>	
<i>Insulation classification</i>	
<i>Degree of protection</i>	
<i>Mounting arrangements</i>	
<i>Motor feet</i>	
<i>Terminal box</i>	
<i>Vibration and acoustic level</i>	
<i>Housing, endshields</i>	
<i>Permissible loading on the shaft end</i>	
<i>Bearings</i>	
<i>Cooling system</i>	
<i>Ordering information</i>	
<hr/>	
Data tables	pages 13-17
<hr/>	
Dimension drawings	pages 18-28
<hr/>	
List of motor parts	pages 29-31
<hr/>	
Production program	pages 34-35
<hr/>	

DESCRIPTION OF THE CATALOGUE VERSION

Duty:	S1
Rated voltage:	380V, 400V, 690V (/Y)
Frequency:	50 Hz
Ambient temperature:	from -15°C to + 40°C
Mounting height:	up to 1000 m above sea level
Number of free shaft ends:	1
Insulation class:	F
Bearings:	according to page 12

Other specifications dependent on the frame size:

Frame size	Degree of protection	Position of the terminal box	Number of terminals	Number of cable outlets	Optional rotation of the terminal box	Glands	Temperature sensors in winding	Bearing lubrication system	Thermal protection of bearings
Sg 56	IP 55	top	6	1	180°	M 20	on request	no	no
Sg 63	IP 55	top	6	1	180°	M 20	on request	no	no
Sh 71	IP 55	top	6	1	180°	M 20	on request	no	no
Sh 80	IP 55	top	6	1	180°	M 20	on request	no	no
Sh 90	IP 55	top	6	2	180°	M 20	on request	no	no
Sg 100	IP 55	top	6	2	180°	M 20	on request	no	no
Sg 112	IP 55	top	6	2	180°	M 25	on request	no	no
Sg 132	IP 55	top	6	2	180°	M 25	on request	no	no
Sg 160	IP 55	top	6	2	180°	M 40	on request	on request	on request
Sg 180	IP 55	top	6	2	180°	M 40	on request	on request	on request
Sg 200	IP 55	right	6	2	4 × 90°	M 50	PTC	yes	on request
Sg 225	IP 55	right	6	2	4 × 90°	M 50	PTC	yes	on request
Sg 250	IP 55	right	6	2	4 × 90°	M 63	PTC	yes	on request
Sg 280	IP 55	right	6	2	4 × 90°	M 63	PTC	yes	on request
Sg 315	IP 55	right	6	2	4 × 90°	M 76	PTC	yes	on request
SEE 315	IP 55	top	6	2	4 × 90°	M 76	PTC	yes	on request
Sg 355	IP 55	right	6	2	4 × 90°	M 76	PTC Mark A	yes	on request
SEE 355	IP 55	top	6	2	4 × 90°	M 76	PTC Mark A	yes	on request
Sh 355	IP 55	top	6	2	4 × 90°	M 76	Pt 100	yes	Pt 100
Sh 400	IP 55	top	3 (bars)	3	180°	3× 55	Pt 100	yes	Pt 100
Sh 450	IP 55	top	3 (bars)	3	180°	3× 55	Pt 100	yes	Pt 100
Sh 500	IP 55	top	3 (bars)	3	180°	3× 55	Pt 100	yes	Pt 100

We are able to supply almost any motor made according to customer's specifications

DESCRIPTION OF THE CUSTOMISED VERSION

Different supply voltage	
Frequency:	60 Hz
Degree of protection:	IP 56
Insulation class:	H
Number of free shaft ends:	2
Tropicalization	
Different bearings	
Different duty type	
Adaptation for supply from a frequency inverter	
Different versions per customer's specifications	

As part of our development program, we reserve the right to alter or amend any of the specifications without giving prior notice

RATINGS - TOLERANCES

Permissible deviations of real values from catalogue values according to IEC 60034-1:

Power factor \cos	$\cos = -1/6 (1 - \cos \phi_N)$
Efficiency	$= -15\%(100 - \eta_N)$ for $P_N \leq 50\text{kW}$ $= -10\%(100 - \eta_N)$ for $P_N > 50\text{kW}$
Speed n	$n = \pm 20\%(n_s - n_N)$ for $P_N \leq 1\text{kW}$ $n = \pm 30\%(n_s - n_N)$ for $P_N > 1\text{kW}$
Locked rotor current I_r/I_N	$(I_r/I_N) = +20\% (I_r/I_N)$
Locked rotor torque M_r/M_N	$\min (M_r/M_N) = -15\% (M_r/M_N)$ $\max (M_r/M_N) = +25\% (M_r/M_N)$
Breakdown torque M_{\max}/M_N	$(M_{\max}/M_N) = -10\% (M_{\max}/M_N)$
Moment of inertia J [kgm^2]	$J = \pm 10\% J$
Sound pressure level L_{pA} [dB]	$L_{pA} = +3 \text{ dB /A}$

The efficiency of motors of frame size 56 - 180 is determined by method of total loss measurement, and the efficiency of motors of frame size 200 - 500 is determined by method of summary of losses.

The rated current of a motor is the value consumed by a given motor at the rated load, rated supply voltage, rated efficiency and power factor.

Real current consumed by the motor at the rated supply voltage and rated load results from the real efficiency and real power factor (permissible deviations).

No-load current in small motors and low speeds, e.g. frame size 90, $2p=6$ or $2p=8$, may be approximately slightly lower or equal to the rated current. In case of supply voltage higher than the rated one it may even exceed the rated current.

STANDARDS AND EQUIVALENTS

The electric motors are manufactured according to international standards:

		Country	Standard
Rating and performance	IEC 60034-1	Germany	DIN VDE 0530; DIN EN 60034/VDE; DIN IEC 34; DIN 42673; DIN 42677
Methods for determining losses and efficiency	IEC 60034-2		
Classification of degrees of protection	IEC 60034-5	Great Britain	BS 5000; BS 4999
Methods of cooling	IEC 60034-6		
Symbols of construction and mounting arrangements	IEC 60034-7	France	NFC 51 111 51 120; NFC 51 200; NFC 51 115 NFC 51 117; NFC 51 119
Terminal markings and direction of rotation	IEC 60034-8		
Noise limits	IEC 60034-9		
Dimensions and output for electric machines	IEC 60072-1	Italy	CEI 2-3 1988; CEI 2-6; CEI 2-7 CEI 2-8; CEI 2-15 CEI/UNEL 13113-71; CEI/UNEL 13117-71; CEI/UNEL 13118-71;
Vibration limits	IEC 60034-14		

The products comply with the specifications regarding the electromagnetic compatibility specified in:
EN 61000-6-1, EN 61000-6-2, EN 61000-6-3, EN 61000-6-4.

All the motors are manufactured in Quality Assurance System consistent with ISO 9001.

ISO9001

The motors covered by the present catalogue comply with the regulations and standards effective in other countries, consistent with IEC standards.

IEC

All the motors described in the present catalogue are provided with CE mark. It means that our products are consistent with the European Union directives regarding the safety measures.

CE



Cantoni Motor has in offer not only general purpose standard efficiency motors Sg (Sh) series which fulfill IE1 class requirements according to the IEC 60034-30 standard, but also high efficiency motors (with higher efficiency level) which fulfill IE2 class requirements according to the above mentioned IEC standard.

The present catalogue mostly describes the electric motors belonging to the efficiency class IE1 (standard efficiency).

These motors show high efficiency, exceeding average efficiency of motors manufactured by other European manufacturers.

New international efficiency classes of motors (IE = International Efficiency).
 The new EN 60034-30:2009 defines worldwide the efficiency classes of motors:
 IE1 - Standard Efficiency (comparable to EFF2)
 IE2 - High Efficiency (comparable to EFF1)
 IE3 - Premium Efficiency.

Comparison between efficiency of Cantoni Group motors (example 2p=4) and efficiency class IE1/IE2 according to IEC 60034-30.

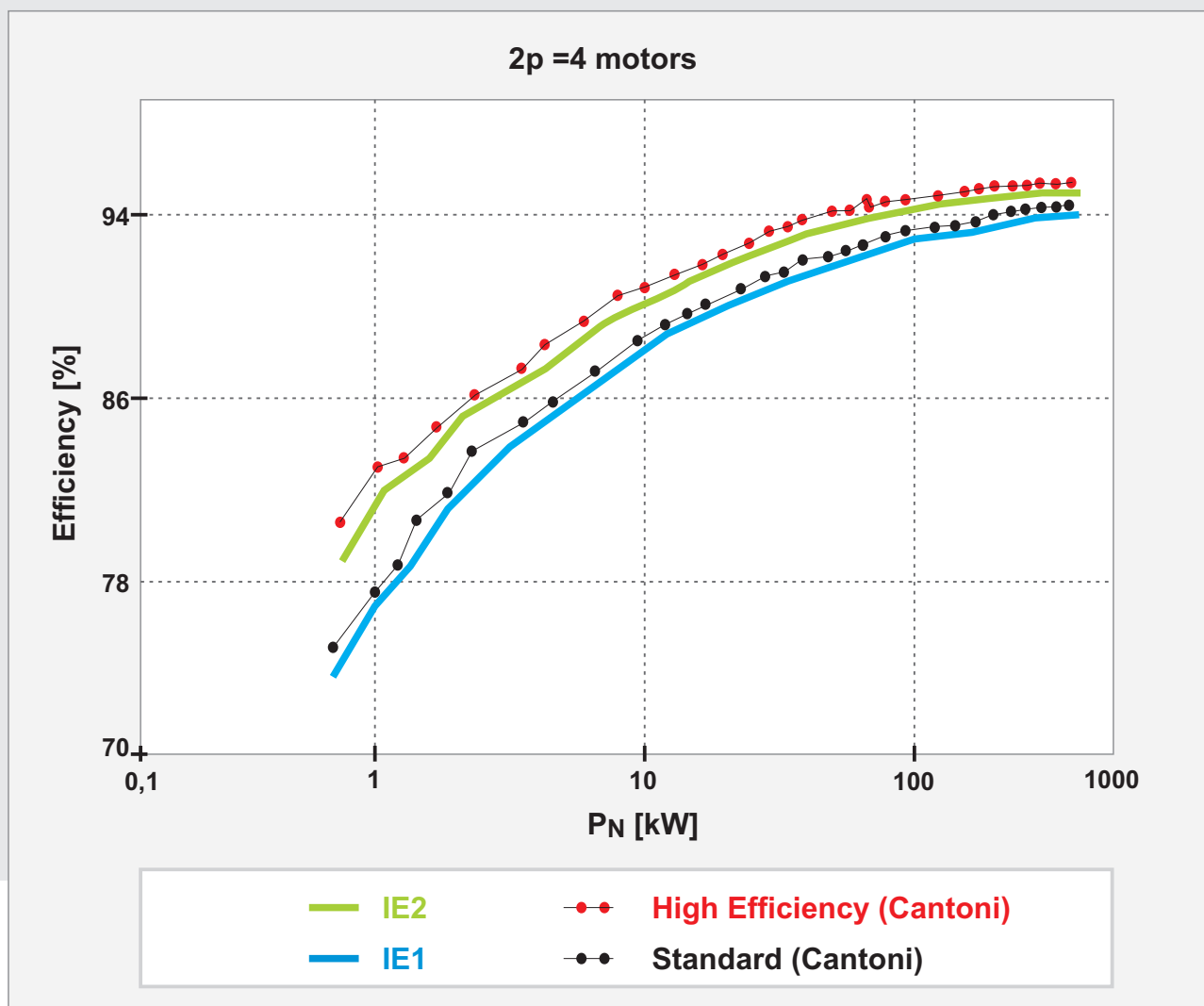

For example - high efficiency motor type SEE 90S-4 (1,1kW) at S1 continuous work (24h per day) will consume 6600kWh during one year of operation. In this case, taking into consideration motor price and energy cost, total time of investment return will be about 1/2 of year.

INSULATION CLASSIFICATION

The insulation system of an electric motor is determined by a given insulation class on the basis of its thermal resistance. This thermal resistance should be guaranteed by the entire set of electric insulating materials used in the motor insulating system.

Thermal resistance classification is related to the temperature of the hotspot in the insulation occurring during rated operating conditions of the electric motor, allowing for the highest permissible rise in average temperature.

This rise should be selected so that at the highest permissible ambient temperature, the temperature of the hotspot in insulation will not exceed the value assigned to a given thermal resistance class.

Symbols of thermal resistance classes (permissible insulation temperatures for ambient temperature of 40°C)

Symbol	Temperature [°C]
A	105
E	120
B	130
F	155
H	180

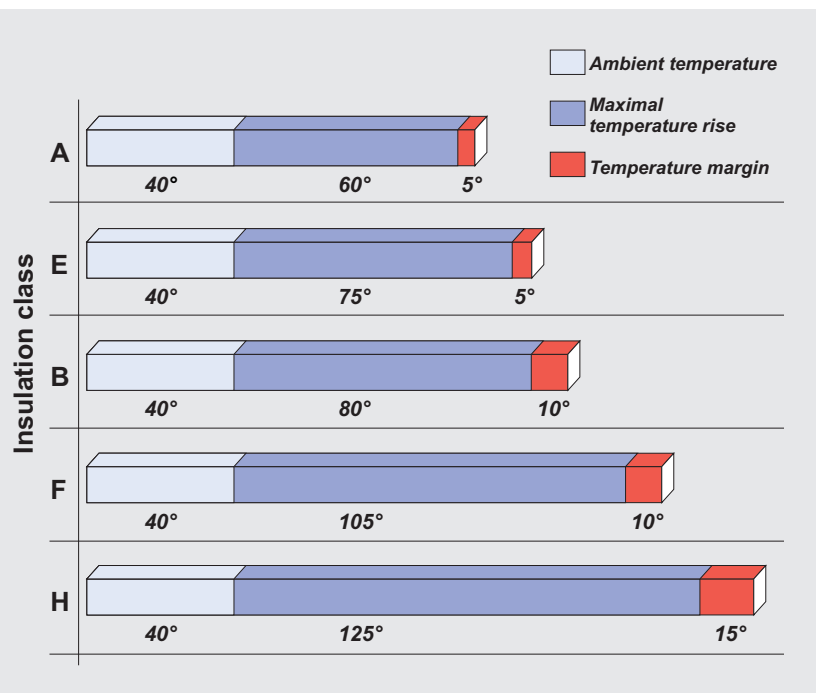

Insulation class F for an electric motor means that at ambient temperature of 40°C the temperature rise of its windings may be max. 105°C with the additional temperature margin of 10°C (under specified measuring conditions in accordance with the IEC 60034-1 standard).

Class F

The motors made by Cantoni Motor in their basic version have the insulation class F while the temperature rise is for class B. It means longer life of motors.

On customer's demand, we make motors with insulation class H.

Strengthened insulation system makes it possible to supply our motors from frequency inverters.

DEGREE OF PROTECTION IP

According to the IEC 60034-5 standard the electric motors are provided with IP code which determines the degree of protection ensured by the housing against access to dangerous parts, introducing foreign matter and/or water.

The IP code consists of IP code letters and two obligatory digits, meaning:

The first digit (protection from introduction Of solid foreign matter)		The second digit (protection against penetration of water and its harmful effects)	
IP	Definition	IP	Definition
0	no protection	0	no protection
1	diameter 50 mm	1	dropping vertically
2	diameter 12,5 mm	2	dropping (up to 15°)
3	diameter 2,5 mm	3	sprayed
4	diameter 1,0 mm	4	splashed
5	limited protection against dust	5	in stream
		6	in strong stream
		7	under short-time immersion
		8	under permanent immersion

The motors described in the present catalogue in their basic version have the IP 55 degree of protection.

On demand we make motors with the IP 56 degree of protection.

IP55

MOUNTING ARRANGEMENTS

According to the IEC 60034-7 standard

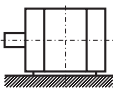
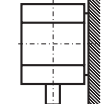
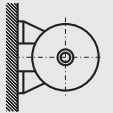
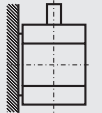
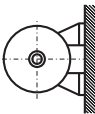
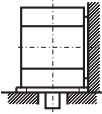
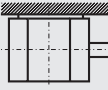
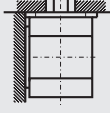
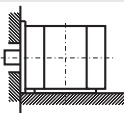
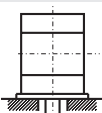
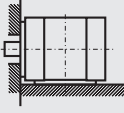
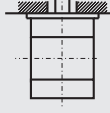
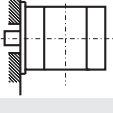
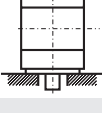
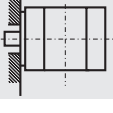
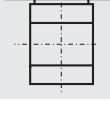
	Horizontal shaft			Vertical shaft			
	Designation		Frame size	Designation		Frame size	
	Code II	Code I			Code II		Code I
	IM 1001	IM B3	56 ÷ 500		IM 1011	IM V5	56 ÷ 315 except Sg 315 M6C except Sg 315 M8C
	IM 1051	IM B6	56 ÷ 280		IM 1031	IM V6	56 ÷ 315 except Sg 315 M6C except Sg 315 M8C
	IM 1061	IM B7	56 ÷ 280		IM 2011 or IM 2111	IM V15	56 ÷ 315 except SLg 315 M6C except SLg 315 M8C
	IM 1071	IM B8	56 ÷ 280		IM 2031 or IM 2131	IM V36	56 ÷ 315 except SLg 315 M6C except SLg 315 M8C
	IM 2001	IM B35	56 ÷ 500		IM 3011	IM V1	56 ÷ 500 except SVEE 355 (2-pole) except SVh 355 (2-pole) except SVh 400 (2-pole)
	IM 2101	IM B34	56 ÷ 132		IM 3031	IM V3	56 ÷ 280
	IM 3001	IM B5	56 ÷ 315 except SKg 315 M6C except SKg 315 M8C		IM 3611	IM V18	56 ÷ 180
	IM 3601	IM B14	56 ÷ 132		IM 3631	IM V19	56 ÷ 180

MOUNTING ARRANGEMENTS

MOTOR FEET

Motors of frame size 112 have screwed feet.
 Motors of frame size 132 have screwed feet or integrated with the motor housing.
 Motors of frame size 160 have feet integrated with the motor housing.

TERMINAL BOX

Terminal boxes of low voltage motors have threaded inlet holes designed for mounting cable glands. The box contains terminal board with marked terminals making possible connection of supply cables.

In addition, terminal boxes may be provided with additional terminals connected to the ends of thermal protection or anticondensation heater circuits and extra glands to connect these circuits.

Low voltage high-power motors contain terminal boxes with cable gland seals and cable clamps to prevent their removal. Inside the boxes there are special clamps used to ground the supply cable armouring.

In low voltage motors of very high power three supply busbar are used.

Box covers of low voltage high-power motors are made in form of antiimplosion membranes. The circuits of thermal protection and anticondensation heaters are connected to separate terminal boxes.

VIBRATION LEVEL AND ACOUSTIC POWER

VN

The rotor balancing method guarantees maintaining a normal vibration level VN in accordance with the IEC 60034-14 standard and basic acoustic power level in accordance with the IEC 60034-9 standard. On customer's demand the motors may be made with reduced vibration or noise level.

HOUSING, END SHIELDS, FEET

Frame size [mm]	Motor housing	End shields	Feet
56	Aluminium	Aluminium	Aluminium - screwed
63	Aluminium	Aluminium	Aluminium - screwed
71	Aluminium	Aluminium	Aluminium - screwed
80	Aluminium	Aluminium	Aluminium - screwed
90	Aluminium	Aluminium	Aluminium - screwed
100	Aluminium	Aluminium	Aluminium - screwed
112	Aluminium	Cast iron	Aluminium - screwed
132	Cast iron	Cast iron	Cast iron - screwed
160	Cast iron	Cast iron	Cast iron - integrated
180	Cast iron	Cast iron	Cast iron - integrated
200	Cast iron	Cast iron	Cast iron - integrated
225	Cast iron	Cast iron	Cast iron - integrated
250	Cast iron	Cast iron	Cast iron - integrated
280	Cast iron	Cast iron	Cast iron - integrated
315	Cast iron	Cast iron	Cast iron - integrated
355	Cast iron	Cast iron	Cast iron - integrated
400	Cast iron	Cast iron	Cast iron - integrated
450	Cast iron	Cast iron	Cast iron - integrated
500	Cast iron	Cast iron	Cast iron - integrated

In motors of frame size 80, 90 and 100: on request end shields may be made of cast iron.

In motors of frame size 132: feet may be integrated with housing.

Motor housing

 aluminium  cast iron

aluminium

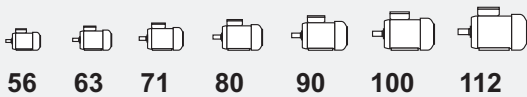

cast iron

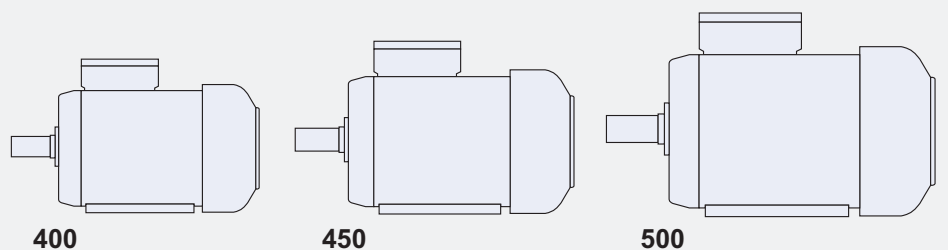
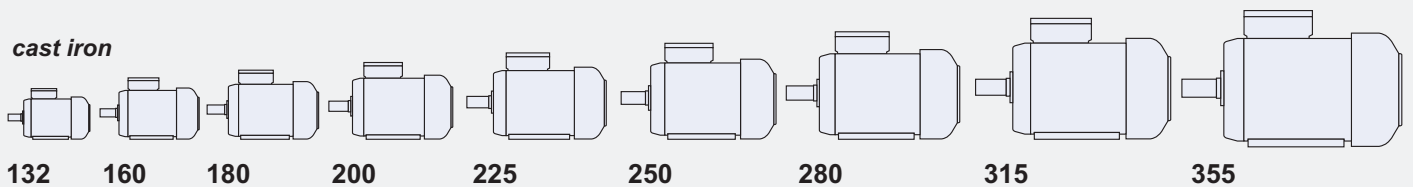

PERMISSIBLE LOADING ON THE SHAFT END

Frame size	Number of poles	Horizontal operation		Vertical operation			Frame size	Number of poles	Horizontal operation		Vertical operation		
		$F_R(x=0)$	$F_R(x=\max)$	F_p	F_{a1}	F_{a2}			$F_R(x=0)$	$F_R(x=\max)$	F_p	F_{a1}	F_{a2}
		[kN]			[kN]				[kN]			[kN]	
Sg 56	2	0,20	0,16	0,04	0,03	0,05	Sg 200 LB	6	2,70	2,20	2,40	1,60	3,40
Sg 56	4	0,25	0,20	0,05	0,04	0,06	Sg 200 L	8	3,10	2,60	2,7	2,00	3,60
Sg 63	2	0,20	0,16	0,04	0,04	0,06	Sg 225 S	4	2,90	2,30	2,50	1,80	3,40
Sg 63	4	0,25	0,20	0,06	0,05	0,07	Sg 225 S	8	3,90	3,10	3,20	2,50	4,20
Sg 63	6	0,27	0,22	0,06	0,05	0,07	Sg 225 M	2	2,20	1,80	1,70	1,10	2,50
Sh 71	2	0,29	0,24	0,07	0,05	0,09	Sg 225 M	4	2,70	2,10	2,40	1,60	3,50
Sh 71	4	0,36	0,30	0,09	0,07	0,11	Sg 225 M	6	3,10	2,50	2,80	1,90	4,00
Sh 71	6	0,40	0,35	0,10	0,08	0,12	Sg 225 M	8	3,70	2,90	3,10	2,30	4,30
Sh 71	8	0,40	0,35	0,11	0,09	0,13	Sg 250 M	2	2,60	2,10	2,00	1,30	3,00
Sh 80	2	0,33	0,27	0,09	0,06	0,12	Sg 250 M	4	3,20	2,60	2,80	1,80	4,20
Sh 80	4	0,44	0,37	0,12	0,09	0,15	Sg 250 M	6	3,60	2,90	3,20	2,00	4,90
Sh 80	6	0,51	0,42	0,14	0,11	0,17	Sg 250 M	8	4,10	3,40	3,60	2,30	5,30
Sh 80	8	0,51	0,42	0,17	0,15	0,20	Sg 280 S	2	3,20	2,70	2,60	1,40	4,00
Sh 90	2	0,58	0,44	0,53	0,30	0,40	Sg 280 S	4	3,90	3,30	3,50	2,10	5,40
Sh 90	4	0,64	0,52	0,60	0,30	0,40	Sg 280 S	6	5,00	4,20	4,20	2,90	5,90
Sh 90	6	0,74	0,68	0,73	0,30	0,40	Sg 280 S	8	5,50	4,60	4,60	3,30	6,50
Sh 90	8	0,82	0,74	0,80	0,30	0,40	Sg 280 M	2	3,10	2,50	2,50	1,30	4,10
Sg 100	2	0,78	0,56	0,70	0,25	0,40	Sg 280 M	4	3,70	3,10	3,50	1,90	5,50
Sg 100	4	0,81	0,79	0,83	0,25	0,40	Sg 280 M	6	4,80	4,00	4,10	2,70	6,10
Sg 100	6	0,98	0,92	0,98	0,25	0,40	Sg 280 M	8	5,20	4,30	4,50	2,90	6,70
Sg 100	8	1,12	1,04	1,11	0,25	0,40	Sg 315 S	2	3,70	3,20	3,00	1,60	4,80
Sg 112	2	0,70	0,56	0,67	0,25	0,40	Sg 315 S	4	6,40	5,30	4,90	3,10	7,30
Sg 112	4	0,81	0,71	0,79	0,25	0,40	Sg 315 S	6	7,40	6,20	6,30	4,30	8,90
Sg 112	6	0,92	0,84	0,92	0,25	0,40	Sg 315 S	8	8,40	7,00	7,00	5,00	9,60
Sg 112	8	1,05	0,97	1,05	0,25	0,40	Sg 315 MA	2	3,60	3,00	2,90	1,50	4,80
Sg 132	2	1,02	0,94	1,04	0,17	0,57	Sg 315 MB	2	3,30	2,80	2,90	1,30	4,90
Sg 132	4	1,16	1,04	1,16	0,17	0,57	Sg 315 MA	4	6,20	5,10	4,80	2,90	7,40
Sg 132	6	1,40	1,22	1,37	0,17	0,57	Sg 315 MB	4	5,90	4,90	4,80	2,70	7,50
Sg 132	8	1,63	1,39	1,57	0,17	0,57	Sg 315 MA	6	7,20	6,00	6,20	4,10	9,00
Sg 160	2	1,23	1,09	1,22	0,82	1,07	Sg 315 MB	6	6,80	5,60	6,10	3,60	9,30
Sg 160	4	1,35	1,13	1,32	1,00	1,39	Sg 315 MA	8	8,20	6,80	6,90	4,80	9,70
Sg 160	6	1,61	1,37	1,58	1,26	1,62	Sg 315 MB	8	7,70	6,40	6,80	4,30	10,00
Sg 160	8	1,92	1,50	1,80	1,47	1,80	SEE 315MC	2	2,90	2,50	2,80	1,00	5,10
Sg 180	2	1,90	1,66	1,65	1,00	1,20	SEE 315MC	4	7,50	6,30	4,70	2,60	7,40
Sg 180	4	2,42	1,82	1,98	1,00	1,35	SEE 315MD	6	8,30	6,90	5,30	2,50	9,00
Sg 180	6	2,75	2,07	2,15	1,60	1,95	SEE 315MD	8	9,40	7,80	5,90	3,10	9,60
Sg 180	8	3,30	2,04	2,49	1,90	2,44	SEE 355	adaptation to belt drive on customer's request					
Sg 200 LA	2	2,00	1,60	1,50	1,10	2,10	Sg 355	adaptation to belt drive on customer's request					
Sg 200 LB	2	1,80	1,50	1,50	1,00	2,10	Sh 355	adaptation to belt drive on customer's request					
Sg 200 L	4	2,40	1,90	2,10	1,50	2,90	Sh 400	adaptation to belt drive on customer's request					
Sg 200LA	6	2,80	2,30	2,40	1,80	3,30	Sh 450	adaptation to belt drive on customer's request					
							Sh 500	adaptation to belt drive on customer's request					

Value of radial force F_R acting on the shaft end for a given belt pulley diameter is calculated according to the following formula:

$$F_R = \frac{19600 \times P \times k}{D_k \times n} \text{ [N]}$$

- where: P - motor output [kW]
 D_k - belt pulley diameter [m]
 n - speed [rpm]
 k - belt tension factor:
 for V-belts $k=2,2$
 for flat belts $k=3$

Value of force F_R acting on any point of the shaft end (between points $X=\max$ and $X=0$) may be calculated according to the following formula:

$$F_R = F_{X0} - \frac{X}{E} \times (F_{X0} - F_{XMAX}) \text{ [N]}$$

- where: F_{X0} - value of F_R force acting on the beginning of the shaft end
 F_{XMAX} - value of F_R force acting on the end of the shaft end
 E - length of the shaft end

BEARINGS

Frame size	Number of poles	Bearings
Sg 56	2 ÷ 6	6201 2Z
Sg 63	2 ÷ 8	6202 2Z
Sh 71	2 ÷ 8	6203 2Z
Sh 80	2 ÷ 8	6204 2Z
Sh 90	2 ÷ 8	6205 2Z
Sg 100	2 ÷ 8	6206 2Z
Sg 112	2 ÷ 8	6306 2Z
Sg 132	2 ÷ 8	6308 2Z
Sg 160	2 ÷ 8	6309 2Z
Sg 180	2 ÷ 8	6311 2Z
Sg 200	2 ÷ 12	6212 C3
Sg 225	2 ÷ 12	6213 C3
Sg 250	2 ÷ 12	6215 C3
Sg 280	2	6217 C3
Sg 280	4 ÷ 12	6217 C3
Sg 315	2	6315 C3
Sg 315	4 ÷ 12	6318 C3

The bearings in basic version of motors for horizontal duty.

COOLING SYSTEM

Standard motors in frame size 56 ÷ 500 are being cooled down by means of a fan installed on the shaft from the non-drive end, covered with steel cover, cooling system IC 411 according to the IEC 60034-6 standard.

The design of fans and fan covers as well as materials used ensure optimum utilization of their aerodynamic and aeroacoustic properties.

Standard motors can operate in both directions of rotation, with the exception of Sh 355, 400, 450, 500 (2 and 4 poles) motors where unidirectional fans are applied.

ORDERING INFORMATION

Orders for motors should specify:

- motor type designation,
- rated output,
- rated speed,
- operating duty,
- supply voltage and connection,
- frequency,
- mounting arrangements, end shield material,
- degree of protection,
- machine to be driven,
- other details of out-of-catalogue or special version,

and information concerning additional accessories e.g.

- thermal protection,
- anticondensation heaters,
- vibration sensors,
- etc.

Frame size		Number of poles	Bearings
Sg 315 MC	DE	6 ÷ 8	NU320 EM1
	NDE		6320 C3
SEE 315		2	6315 2ZC3
SEE 315	DE	4 ÷ 8	6320 2ZC3
	NDE		6318 2ZC3
Sg 355		2	6317 C3
Sg 355	DE	4 ÷ 12	NU322 C3
	NDE		6322 C3
SEE 355		2	6217 C3
SEE 355		4 ÷ 8	6222 C3
Sh 355		2	6217 C3
Sh 355		4 ÷ 8	6322 C3
Sh 400		2	6218 C3
Sh 400	DE	4 ÷ 8	6324 MC3
	NDE		6322 MC3
Sh 450	DE	4 ÷ 10	6324 MC3
	NDE		NU222 EM1
Sh 500	DE	4 ÷ 10	NU226 EM1+ 6226 C3
	NDE		NU226 EM1

DE - drive end NDE - non drive end

When ordering high-power or special purpose motors one should also indicate:

- required direction of rotation,
- required degree of interior protection,
- method of start-up,
- method of coupling with the driven unit (gears, dimensions of belt pulleys, etc.),
- type of driven machine (nature of load), including the moment of inertia J or flywheel effect GD² brought to the motor shaft,
- other customer's specifications.

When ordering spare parts one should specify:

- full designation of the motor type including its serial number (provided on the nameplate) or catalogue number,
- degree of protection,
- mounting form,
- name of part,
- number of pieces.

Totally Enclosed Motors IP 55

Item	Type	Rated output		Rated speed	Rated torque	Efficiency			Power factor	Full load current			Locked rotor torque	Locked rotor current	Breakdown torque	Moment of Inertia	Sound power level	Sound pressure level	Weight (IMB3)
		P _N	η _N			T _N	N [%] at % of full load			I _N at rated voltage									
		[kW]	[HP]	[min ⁻¹]	[Nm]	50%	75%	100%	cos φ _N	[A] _{230V}	[A] _{380V}	[A] _{400V}	T _L /T _N	I _L /I _N	T _b /T _N	J	L _{WA}	L _{PA}	m
2p=2 n_s=3000 rpm																			
1.	Sg 56-2A	0,09	0,12	2800	0,307	43	50	60	0,65	0,58	0,33	0,33	2,4	3,7	2,4	0,000076	67	60	3
2.	Sg 56-2B	0,12	0,17	2800	0,409	50	58	65	0,75	0,62	0,36	0,36	1,8	3,8	2,1	0,000095	67	60	3,2
3.	Sg 63-2A	0,18	0,25	2760	0,623	58	63	65	0,8	0,95	0,55	0,55	1,9	3,8	1,9	0,000175	67	60	3,6
4.	Sg 63-2B	0,25	0,33	2760	0,865	62	65	68	0,83	1,1	0,65	0,65	2,0	4	2,0	0,000235	67	60	4,2
5.	Sh 71-2A	0,37	0,5	2800	1,262	67	69	71	0,77	1,73	1	1	2,2	4,4	2,2	0,000389	67	60	5
6.	Sh 71-2B	0,55	0,75	2790	1,883	69	72	75	0,82	2,35	1,35	1,35	2	4	2,1	0,000484	67	60	6
7.	Sh 80-2A	0,75	1	2800	2,56	66	72	74	0,80	3,3	1,9	1,9	2,7	4,5	2,6	0,000829	72	65	7,8
8.	Sh 80-2B	1,1	1,5	2780	3,78	69	75	77	0,84	4,3	2,5	2,5	2,6	5,1	2,6	0,001005	72	65	9,1
9.	Sh 90S-2	1,5	2,0	2835	5,1	80,7	82,1	81,1	0,83	5,5	3,4	3,2	3	6,1	3	0,0013	78	68	14
10.	Sh 90L-2	2,2	3,0	2855	7,40	82,2	83,9	83,2	0,82	8,1	4,9	4,7	3,4	7,1	3,5	0,002	78	68	16,8
11.	Sg 100L-2	3,0	4,0	2905	9,9	80,9	83,2	83,4	0,86	10,6	6,4	6,0	2,7	7,5	2,8	0,0048	81	71	25
12.	Sg 112M-2	4	5,5	2865	13,33	85,7	86,4	85,4	0,9	-	7,9	7,5	2,1	6,4	2,3	0,0079	81	71	34
13.	Sg 132S-2A	5,5	7,5	2910	18,0	86,4	87,5	87,0	0,88	-	10,9	10,4	2,4	7	3,2	0,0150	81	70	60
14.	Sg 132S-2B	7,5	10	2920	24,53	88,1	89,2	88,5	0,88	-	14,6	13,9	2,5	7,5	3,2	0,0180	85	74	71
15.	Sg 160M-2A	11	15	2930	35,70	88,3	89,6	90,0	0,87	-	20,9	20,3	2,2	7,7	3,4	0,042	84	73	96
16.	Sg 160M-2B	15	20	2920	49,06	90	90,8	90,5	0,91	-	27,7	26,2	2,4	6,2	2,7	0,048	86	75	115
17.	Sg 160L-2	18,5	25	2930	60,3	90,7	91,4	90,3	0,91	-	34,2	32,5	2,1	6,8	2,9	0,059	84	73	119
18.	Sg 180M-2	22	30	2920	71,95	89,5	90,8	90,6	0,88	-	41,9	39,8	2,5	6,0	2,5	0,076	88	77	165
19.	Sg 200L2A	30	40	2960	97	92,3	93	92,9	0,89	-	55	52	1,9	6,0	2,3	0,15	88	78	245
20.	Sg 200L2B	37	50	2960	119	93,4	93,8	93,7	0,89	-	67	64	2,2	6,7	2,5	0,18	88	78	265
21.	Sg 225M2	45	60	2968	145	93,8	94,6	94,5	0,89	-	81	77	2,4	7	2,5	0,26	89	79	335
22.	Sg 250M2	55	75	2970	177	91,6	93	93,5	0,9	-	99	94	2	6,9	2,4	0,36	91	81	410
23.	Sg 280S2	75	100	2977	241	92,5	93,8	94	0,9	-	135	128	2,1	7,5	3,3	0,76	92	82	535
24.	Sg 280M2	90	125	2970	289	93	94,2	94,7	0,91	-	159	151	2	7	3,2	0,87	92	82	605
25.	Sg 315S2	110	150	2975	353	94,6	95,3	95,4	0,92	-	190	181	1,8	8	2,6	0,91	92	82	690
26.	Sg 315M2A	132	175	2975	424	94,5	95,1	95	0,91	-	232	220	2,1	8,5	2,8	0,98	92	82	725
27.	Sg 315M2B	160	220	2975	514	95,5	95,9	95,4	0,89	-	286	272	2,3	9,1	2,5	1,2	92	82	790
28.	SEE 315M2C ¹	200	270	2971	643	96	96,3	96	0,93	-	340	323	2,0	7,1	2,8	1,51	92	82	1030
29.	Sg 355S2	200	270	2976	642	94	95,3	94,8	0,89	-	-	342	1,6	6,6	2,8	2,6	95	85	1350
30.	SEE 355ML2A	250	340	2982	801	95,5	96,3	96,4	0,91	-	-	415	1,8	7	2,8	2,7	93	83	1530
31.	SEE 355ML2B	315	430	2982	1009	95,9	96,6	96,6	0,91	-	-	517	1,9	7,3	3,0	3,3	93	83	1680
32.	Sh 355H2Ds	355	480	2985	1136	95,5	96,3	96,5	0,91	-	-	584	1,7	7,4	2,7	4,9	93	83	2140
33.	Sh 355H2Es	400	540	2985	1280	95,5	96,6	96,7	0,91	-	-	656	1,6	8	2,8	5,3	93	83	2160
34.	Sh 400H2Cs	450	610	2983	1440	95,5	96,3	96,5	0,91	-	-	741	1,3	6,6	2,6	6,5	93	84	2800
35.	Sh 400H2Ds	500	680	2985	1599	95,8	96,5	96,6	0,91	-	-	821	1,4	7,2	2,8	7,3	93	84	2800
36.	Sh 400H2Es	560	760	2989	1789	95,9	96,7	96,9	0,9	-	-	927	1,7	8	3	8,6	94	84	3000

¹ - insulation class H

TECHNICAL DATA

Totally Enclosed Motors IP 55

TECHNICAL DATA

Item	Type	Rated output		Rated speed n_N	Rated torque T_N	Efficiency			Power factor $\cos \phi_N$	Full load current			Locked rotor torque T_L/T_N	Locked rotor current I_L/I_N	Breakdown torque T_b/T_N	Moment of inertia J	Sound power level		Weight (IMB3) m
		P_N	P_N			η_N at % of full load				I_N at rated voltage							L_{WA}	L_{PA}	
		[kW]	[HP]	[min ⁻¹]	[Nm]	50%	75%	100%	[-]	[A] _{230V}	[A] _{380V}	[A] _{400V}	[-]	[-]	[-]	[kgm ²]	[dB]	[dB]	[kg]
2p=4 n_s=1500 rpm																			
37.	Sg 56-4A	0,06	0,08	1400	0,409	44	52	55	0,66	0,43	0,25	0,25	1,8	3,3	2	0,00015	56	49	2,6
38.	Sg 56-4B	0,09	0,12	1380	0,623	54	58	61	0,65	0,59	0,34	0,34	2	3,2	1,9	0,00019	56	49	2,9
39.	Sg 63-4A	0,12	0,17	1380	0,83	56	60	60	0,65	0,8	0,45	0,45	2	3,2	2	0,00024	58	51	3,6
40.	Sg 63-4B	0,18	0,25	1380	1,246	60	62	64	0,63	1,1	0,65	0,65	2	3,2	2	0,00031	58	51	4,2
41.	Sh 71-4A	0,25	0,33	1380	1,73	60	63	66	0,64	1,5	0,85	0,85	2	3	2	0,00061	58	51	4,8
42.	Sh 71-4B	0,37	0,5	1370	2,598	62	65	68	0,68	2,2	1,3	1,3	2,1	3,1	2,1	0,00077	63	56	5,9
43.	Sh 80-4A	0,55	0,75	1400	3,75	62	68	72	0,71	2,7	1,6	1,7	2,1	3,6	2,1	0,00158	65	58	7,5
44.	Sh 80-4B	0,75	1	1390	5,15	67	73	75	0,73	3,5	2	2	2,1	4	2,1	0,0019	65	58	8,8
45.	Sh 90S-4	1,1	1,5	1405	7,48	75,5	77,8	76,7	0,8	4,5	2,7	2,6	2,2	4,9	2,8	0,0023	66	56	14
46.	Sh 90L-4	1,5	2	1410	10,16	78,1	80	79	0,78	6,1	3,7	3,5	2,5	5,3	2,8	0,0028	66	56	16,5
47.	Sg 100L-4A	2,2	3	1425	14,74	80,2	82,3	82	0,80	8,3	5,1	4,8	2,5	6,1	2,8	0,0058	70	60	25
48.	Sg 100L-4B	3,0	4,0	1415	20,25	81,1	83,1	82,7	0,81	11,4	6,8	6,5	2,6	6,1	2,7	0,0065	70	60	26
49.	Sg 112M-4	4	5,5	1435	26,62	84	85,6	85,1	0,82	-	8,7	8,3	2,6	6,3	3	0,0118	72	62	34
50.	Sg 132S-4	5,5	7,5	1450	36,22	84,3	86,1	85,9	0,84	-	11,6	11	2,2	6,9	3,1	0,029	75	64	62
51.	Sg 132M-4	7,5	10	1450	49,4	87	87,8	87	0,85	-	15,4	14,6	2,4	6,7	3,1	0,035	75	64	73
52.	Sg 160M-4	11	15	1460	71,95	88,2	89,3	89	0,85	-	22,1	21,0	2,3	7	3,1	0,061	74	63	105
53.	Sg 160L-4	15	20	1460	98	89,1	89,9	89,5	0,87	-	29,3	27,8	2,4	7,3	3,2	0,075	77	66	125
54.	Sg 180M-4	18,5	25	1470	120	90	90,9	90,5	0,90	-	34,5	32,8	2,4	6,8	2,9	0,135	80	69	165
55.	Sg 180L-4	22	30	1465	143	90,4	91,3	91	0,90	-	40,8	38,8	2,7	7,3	2,8	0,155	80	69	175
56.	Sg 200L-4	30	40	1472	196	92,4	93	92,5	0,88	-	55	53	2,9	7,1	2,5	0,301	81	70	265
57.	Sg 225S4	37	50	1475	240	92	93	92,6	0,88	-	69	66	2,1	6,3	2,2	0,44	83	73	320
58.	Sg 225M4	45	60	1480	290	93,9	94,3	94	0,88	-	83	79	2,6	7	2,3	0,53	85	73	345
59.	Sg 250M4	55	75	1483	354	93,2	93,9	93,5	0,91	-	98	93	2,4	7,3	2,6	0,79	85	75	425
60.	Sg 280S4	75	100	1485	482	92,5	93,5	94,2	0,90	-	134	128	2,5	7,3	2,5	1,37	85	75	575
61.	Sg 280M4	90	125	1485	579	93,5	94,3	94,8	0,91	-	159	151	2,6	7,3	2,6	1,63	86	75	635
62.	Sg 315S4	110	150	1480	710	94,1	94,4	94,2	0,92	-	193	183	2,3	6,9	2,2	1,67	86	76	720
63.	Sg 315M4A	132	175	1487	848	94,5	95	94,9	0,90	-	235	223	2,3	7,6	2,5	1,84	86	76	750
64.	Sg 315M4B	160	220	1489	1026	94,8	95,4	95,4	0,86	-	293	281	2,7	8,5	2,4	2,24	91	76	870
65.	SEE 315M4C ¹	200	270	1483	1288	95,2	96	95,5	0,91	-	350	332	1,7	6,6	2	3,25	93	81	1000
66.	Sg 355S4	200	270	1488	1283	93,3	94,8	95,1	0,89	-	-	341	1,9	6,3	2,5	5,3	88	84	1440
67.	SEE 355ML4A	250	340	1489	1603	95,8	96,4	96,3	0,89	-	-	424	2,0	7,3	2,4	4,9	88	78	1610
68.	SEE 355ML4B	315	430	1489	2020	96,4	96,7	96,6	0,90	-	-	523	2,2	7,6	2,5	6,2	94	78	1810
69.	Sh 355H4Ds	355	480	1488	2277	96,3	96,7	96,5	0,88	-	-	604	1,6	6,5	2,2	8,2	94	84	2175
70.	Sh 355H4Es	400	540	1489	2565	96,4	96,8	96,7	0,88	-	-	678	1,8	7,0	2,3	9,1	94	84	2275
71.	Sh 400H4Cs	450	610	1490	2884	96,3	96,9	96,9	0,88	-	-	762	1,6	7,6	2,6	12,3	94	82	2920
72.	Sh 400H4Ds	500	680	1491	3200	96,5	97	97	0,86	-	-	856	1,6	7,5	2,6	13,6	94	82	3100
73.	Sh 400H4Es	560	760	1491	3587	96,6	97	97	0,87	-	-	959	1,7	7,6	2,6	15,0	95	82	3220
74.	Sh 400H4Fs	630	850	1491	4035	96,7	97,1	97,1	0,87	-	-	1076	1,9	8,4	2,8	16,5	96	83	3370
75.	Sh 450H4Bs	710	960	1492	4543	96,6	97,1	97,1	0,88	-	-	696 ²	1,0	7,0	2,5	27,1	96	84	4000
76.	Sh 450H4Cs	800	1080	1493	5117	96,8	97,1	97,1	0,89	-	-	774 ²	1,6	6,8	2,6	30,8	96	84	4240
77.	Sh 450H4Ds	900	1210	1493	6754	96,8	97,2	97,2	0,88	-	-	881 ²	1,0	7,3	2,5	34,4	96	84	4460
78.	Sh 450H4Es	1000	1350	1493	6393	96,8	97,3	97,3	0,89	-	-	966 ²	1,0	7,3	2,5	38,0	96	84	4700
79.	Sh 500H4Cs	1120	1510	1494	7159	96,9	97,4	97,4	0,88	-	-	1095 ²	0,8	6,5	2,4	58,4	96	84	6100
80.	Sh 500H4Ds	1250	1680	1494	7990	96,9	97,5	97,5	0,88	-	-	1220 ²	0,8	6,5	2,4	65,2	96	84	6600
81.	Sh 500H4Es	1400	1880	1494	8949	96,9	97,5	97,5	0,88	-	-	1367 ²	0,8	6,6	2,4	72,2	96	84	6900

¹ - insulation class H
² - at rated voltage 690 V

Totally Enclosed Motors IP 55

Item	Type	Rated output		Rated speed	Rated torque	Efficiency			Power factor	Full load current			Locked rotor torque	Locked rotor current	Breakdown torque	Moment of inertia	Sound power level	Sound pressure level	Weight (IMB3)
		P _N				n _N	T _N	η [%] at % of full load			cos φ _N	I _N at rated voltage							
		[kW]	[HP]	[min ⁻¹]	[Nm]	50%	75%	100%	[-]	[A] _{230V}	[A] _{380V}	[A] _{400V}	[-]	[-]	[-]	[kgm ²]	[dB]	[dB]	[kg]
2p=6 n_s=1000 rpm																			
82.	Sg 56-6B	0,06	0,08	900	0,637	34	36	40	0,65	0,6	0,35	0,35	1,5	1,8	1,6	0,00019	62	55	3,4
83.	Sg 63-6A	0,09	0,12	820	1,05	26	32	40	0,75	0,8	0,45	0,45	1,15	1,9	1,3	0,00024	57	50	3,6
84.	Sg 63-6B	0,12	0,17	880	1,3	40	46	53	0,7	0,85	0,6	0,6	1,1	2,6	1,6	0,00031	62	55	4,2
85.	Sh 71-6A	0,18	0,25	890	1,93	47	54	57	0,68	1,3	0,75	0,75	1,9	2,6	1,9	0,00074	57	50	4,8
86.	Sh 71-6B	0,25	0,33	860	2,78	45	52	55	0,79	1,75	1	1	1,6	2,0	1,6	0,00095	57	50	5,8
87.	Sh 80-6A	0,37	0,5	910	3,88	61	63	64	0,65	2,4	1,4	1,4	2	3	2,1	0,00169	59	52	7,4
88.	Sh 80-6B	0,55	0,75	900	5,84	62	65	67	0,7	3,1	1,8	1,8	1,9	2,7	2	0,00207	65	58	8,6
89.	Sh 90S-6	0,75	1	915	7,83	70,2	73,3	72,4	0,72	3,6	2,2	2,1	1,9	3,7	2,2	0,002	63	53	13,5
90.	Sh 90L-6	1,1	1,5	920	11,42	73,5	76,2	75,4	0,71	4,6	3,1	3,0	2,2	4	2,2	0,0028	63	53	16,5
91.	Sg 100L-6	1,5	2	945	15,16	74	76,9	76,7	0,73	6,8	4,1	3,9	1,9	4,6	2,3	0,009	74	54	24
92.	Sg 112M-6	2,2	3	960	21,89	81,6	83,8	83,8	0,78	-	5,1	4,9	2,2	5,9	2,8	0,0177	70	60	33
93.	Sg 132S-6	3	4	950	30,16	79,2	81,5	81	0,78	-	7,2	6,9	2,1	5,4	2,8	0,025	73	62	54
94.	Sg 132M-6A	4	5,5	950	40,21	83,5	84,8	84	0,79	-	9,2	8,7	2,4	6	3,1	0,032	73	62	66
95.	Sg 132M-6B	5,5	7,5	950	55,29	84,8	85,9	85	0,79	-	12,4	11,8	2,7	6,3	3,1	0,04	73	62	72
96.	Sg 160M-6	7,5	10	960	74,61	86,6	87,9	87,5	0,81	-	16,1	15,3	2,3	6,5	3,1	0,072	73	62	100
97.	Sg 160L-6	11	15	960	109,4	88,3	89,2	88,5	0,82	-	23	21,9	2,4	7	3,1	0,096	73	62	125
98.	Sg 180L-6	15	20	975	146,9	88	89,2	89	0,84	-	30,5	29,	2,8	6	2,4	0,22	76	65	170
99.	Sg 200L6A	18,5	25	980	180	90	90,8	90,5	0,86	-	36	34,5	2,5	6,8	2,4	0,41	75	63	250
100.	Sg 200L6B	22	30	981	214	90	90,8	90,5	0,88	-	42	40	2,4	6,9	2,2	0,47	73	63	265
101.	Sg 225M6	30	40	982	292	92,3	92,5	91,9	0,88	-	56	54	2,1	6,3	2,2	0,76	73	63	325
102.	Sg 250M6	37	50	985	359	92	92,8	92,5	0,89	-	68	65	2,6	6,8	2,3	1,23	78	68	430
103.	Sg 280S6	45	60	985	436	91,8	93	93	0,87	-	85	80	2	6,5	2,3	1,35	78	68	525
104.	Sg 280M6	55	75	985	533	93,2	93,5	93,5	0,89	-	100	95	2,2	6,2	2,2	1,61	78	68	565
105.	Sg 315S6	75	100	985	727	93,2	93,6	93,5	0,89	-	137	130	2,3	6,6	2,2	2,16	78	68	730
106.	Sg 315M6A	90	125	984	873	92,8	93,8	93,7	0,88	-	166	158	2,5	6,8	2	2,29	78	68	740
107.	Sg 315M6B	110	150	985	1066	93	94	94,2	0,89	-	199	189	2,3	7,2	2,1	2,86	78	68	840
108.	Sg 315M6C	132	175	986	1278	93,7	94,1	94,1	0,87	-	-	233	2	6,1	2,5	5,1	87	78	1065
109.	SEE 315M6D ¹	160	220	980	1559	95	94,9	94,2	0,87	-	-	282	2,7	6	2,3	3,69	92	82	1085
110.	Sg 355S6	160	220	989	1544	94	94,6	94,5	0,86	-	-	284	1,6	5,5	2,2	7,5	89	80	1330
111.	SEE 355ML6A	200	270	989	1931	95,4	95,9	95,7	0,86	-	-	351	2,1	7,0	2,4	6,2	84	75	1720
112.	SEE 355ML6B	250	340	990	2412	95,7	96,1	95,9	0,86	-	-	437	2,2	7,1	2,4	7,7	87	75	1920
113.	Sh 355H6Cs	315	430	992	3032	96,0	96,2	96,1	0,86	-	-	550	1,9	7,0	2,2	11	90	78	2370
114.	Sh 355H6Ds	355	480	991	3421	96	96,2	96,2	0,86	-	-	620	1,8	6,9	2,3	12,3	90	78	2480
115.	Sh 400H6Bs	400	540	992	3851	95,6	96,3	96,3	0,84	-	-	714	1,7	6,8	2,2	16,5	93	81	3050
116.	Sh 400H6Cs	450	610	993	4328	95,8	96,3	96,0	0,85	-	-	315	1,5	7,5	2,5	18,4	93	81	3250
117.	Sh 400H6Ds	500	680	994	4804	95,9	96,4	96,4	0,83	-	-	523 ²	1,7	8,0	2,6	21,5	93	81	3420
118.	Sh 450H6As	500	680	994	4803	96,6	96,9	96,8	0,88	-	-	491 ²	1,2	6,7	2,6	36,5	93	80	3800
119.	Sh 450H6Bs	560	760	994	5379	96,7	97,0	96,9	0,88	-	-	549 ²	1,2	6,8	2,6	40,6	93	80	4300
120.	Sh 450H6Cs	630	850	994	6050	96,7	97,1	97,0	0,89	-	-	611 ²	1,3	7,0	2,6	45,0	93	80	4500
121.	Sh 450H6Ds	710	960	994	6821	96,5	96,8	96,8	0,89	-	-	690 ²	1,4	7,4	2,6	50,0	93	80	4890
122.	Sh 500H6As	800	1080	995	7678	96,7	97,1	97,0	0,86	-	-	802 ²	0,9	5,8	2,2	61,5	93	80	6200
123.	Sh 500H6Bs	900	1210	995	8638	96,8	97,1	97,0	0,87	-	-	893 ²	1,0	6,0	2,2	71,0	93	80	6550
124.	Sh 500H6Cs	1000	1350	995	9598	96,7	97,1	97,1	0,86	-	-	1003 ²	1,1	6,8	2,5	80,0	93	80	6930
125.	Sh 500H6Ds	1120	1510	995	10750	96,7	97,1	97,1	0,87	-	-	1110 ²	1,1	6,9	2,5	86,7	93	80	7220
126.	Sh 500H6Es	1250	1680	995	11997	96,8	97,2	97,2	0,86	-	-	1252 ²	1,1	7,1	2,5	92,5	93	80	7490

¹ - insulation class H
² - at rated voltage 690V

TECHNICAL DATA

Totally Enclosed Motors IP 55

TECHNICAL DATA

Item	Type	Rated output		Rated speed n_N [min ⁻¹]	Rated torque T_N [Nm]	Efficiency			Power factor $\cos \phi_N$ [-]	Full load current			Locked rotor torque T_L/T_N [-]	Locked rotor current I_L/I_N [-]	Breakdown torque T_b/T_N [-]	Moment of inertia J [kgm ²]	Sound power level L_{WA} [dB]	Sound pressure level L_{pA} [dB]	Weight (IMB3) m [kg]
		P_N [kW]	P_N [HP]			η_N [%] at % of full load				I_N at rated voltage									
					50%	75%	100%	[A] _{230V}	[A] _{380V}	[A] _{400V}									
2p=8 $n_s=750$ rpm																			
127.	Sg 63-8A	0,04	0,05	670	0,57	20	31	35	0,6	0,6	0,35	0,35	1,6	1,7	1,7	0,00024	57	50	3,6
128.	Sg 63-8B	0,06	0,08	670	0,85	25	34	38	0,6	0,8	0,45	0,45	1,6	1,7	1,7	0,000307	57	50	4,2
129.	Sh 71-8A	0,09	0,12	680	1,26	25	31	35	0,5	1,3	0,75	0,75	1,9	1,9	1,9	0,000736	57	50	4,9
130.	Sh 71-8B	0,12	0,17	670	1,71	40	45	47	0,63	1,25	0,7	0,7	1,7	1,9	1,8	0,000946	57	50	5,8
131.	Sh 80-8A	0,18	0,25	680	2,53	43	51	53	0,57	1,55	0,9	0,9	1,8	2,3	2,0	0,001693	60	53	7,5
132.	Sh 80-8B	0,25	0,33	680	3,51	52	55	57	0,6	2,1	1,2	1,2	1,7	2,5	1,7	0,00207	60	53	8,9
133.	Sh 90S-8	0,37	0,5	695	5,08	54,2	60,8	63,4	0,59	2,4	1,5	1,4	1,7	2,9	2,3	0,0021	61	51	13,4
134.	Sh 90L-8	0,55	0,75	675	7,78	60,4	65,3	65	0,64	3,3	2	1,9	1,7	2,8	1,9	0,0024	62	52	15,3
135.	Sg 100L-8A	0,75	1	710	10,1	65,9	70,5	71,1	0,66	4	2,4	2,3	1,4	3,5	1,9	0,009	64	54	23,6
136.	Sg 100L-8B	1,1	1,5	705	14,9	67,6	71,8	72,2	0,65	5,9	3,6	3,4	1,6	3,6	1,9	0,01	64	54	26,3
137.	Sg 112M-8	1,5	2	720	19,9	72,5	76,2	76,8	0,71	-	4,2	4,0	1,9	4,6	2,3	0,0192	67	57	31
138.	Sg 132S-8	2,2	3	710	29,6	75,4	78,2	78	0,74	-	5,8	5,5	2,0	4,7	2,4	0,033	71	60	53
139.	Sg 132M-8	3	4	710	40,4	78,5	80,7	80	0,74	-	7,7	7,3	2,3	5,0	3,0	0,044	71	60	65
140.	Sg 160M-8A	4	5,5	705	54,2	81,5	82,7	81,5	0,76	-	9,8	9,3	2,2	5,0	2,7	0,06	72	64	85
141.	Sg 160M-8B	5,5	7,5	710	74	82,1	83,7	83	0,75	-	13,4	12,8	2,7	5,5	3,0	0,077	72	61	95
142.	Sg 160L-8	7,5	10	705	102	84,5	85,5	84,5	0,78	-	17,3	16,4	2,7	5,8	3,0	0,102	72	61	115
143.	Sg 180L-8	11	15	730	144	87,7	89,2	89	0,76	-	24,7	23,5	2,0	5,5	2,4	0,213	76	65	165
144.	Sg 200L8	15	20	733	195	88,8	90	89,5	0,83	-	30,5	29,1	2,2	5,5	2,1	0,45	70	60	255
145.	Sg 225S8	18,5	25	735	240	88,8	90	89,5	0,81	-	39	37	2,0	5,6	2,0	0,58	70	60	280
146.	Sg 225M8	22	30	735	286	90,0	90,8	90,4	0,8	-	46	44	2,0	5,2	1,8	0,68	70	60	315
147.	Sg 250M8	30	40	738	388	91,0	92	91,5	0,84	-	59	56	2,5	6,3	2,1	1,27	75	65	430
148.	Sg 280S8	37	50	737	479	92,0	93,1	92,8	0,83	-	73	69	2,0	5,3	1,8	1,47	75	65	535
149.	Sg 280M8	45	60	737	583	92,0	92,8	92,5	0,84	-	88	84	2,1	5,4	2,0	1,8	75	65	590
150.	Sg 315S8	55	75	735	715	92,0	93,0	92,7	0,81	-	111	106	2,0	5,3	1,9	2,16	75	65	720
151.	Sg 315M8A	75	100	737	972	92,5	93,5	93,2	0,82	-	149	142	2,5	6,2	1,9	2,29	75	65	750
152.	Sg 315M8B	90	125	737	1166	92,5	93,5	93,2	0,82	-	179	170	2,4	6,5	1,9	2,86	75	65	840
153.	Sg 315M8C	110	150	740	1419	92,3	93,1	93,0	0,84	-	-	203	1,6	6,7	2,9	5,1	86	75	1060
154.	SEE 315M8D ¹	132	175	734	1711	92,7	93,3	93,2	0,71	-	-	252	2,3	5,4	2,2	3,69	84	74	1100
155.	Sg 355S8	132	175	741	1701	93,7	94,7	94,8	0,80	-	-	251	1,3	5,5	2,0	7,2	87	77	1320
156.	SEE 355ML8A	160	220	739	2067	95,1	95,5	95,0	0,80	-	-	305	1,6	5,8	2,0	6,1	85	74	1680
157.	SEE 355ML8B	200	270	740	2582	95,1	95,6	95,2	0,79	-	-	384	1,8	6,2	2,1	7,5	85	74	1750
158.	Sh 355H8Ds	250	340	742	3218	95,5	96,0	95,5	0,78	-	-	484	1,3	6,0	2,0	11	88	77	2440
159.	Sh 355H8Es	315	430	743	4049	95,6	96,0	95,8	0,78	-	-	609	1,3	6,0	2,0	13,8	88	77	2590
160.	Sh 400H8Ds	355	480	742	4569	95,3	95,9	95,9	0,77	-	-	402 ²	1,2	5,8	2,0	18,8	89	78	3200
161.	Sh 400H8Es	400	540	742	5148	95,4	96,0	96,0	0,77	-	-	452 ²	1,2	5,9	2,0	21,0	89	78	3350
162.	Sh 450H8Bs	450	610	746	5761	95,5	96,3	96,4	0,78	-	-	501 ²	1,0	5,8	2,1	41,6	89	78	4400
163.	Sh 450H8Cs	500	680	746	6401	95,5	96,3	96,4	0,78	-	-	557 ²	1,0	5,8	2,1	46,0	89	78	4600
164.	Sh 450H8Ds	560	760	746	7169	95,6	96,4	96,5	0,78	-	-	623 ²	1,0	5,7	2,1	49,0	89	78	4770
165.	Sh 450H8Es	630	850	746	8065	95,8	96,4	96,5	0,79	-	-	692 ²	1,0	5,6	2,0	53,8	89	78	4980
166.	Sh 500H8Bs	710	960	746	9089	96,0	96,6	96,6	0,81	-	-	760 ²	1,0	6,0	2,4	85,8	89	78	6500
167.	Sh 500H8Cs	800	1080	746	10241	96,1	96,7	96,7	0,81	-	-	856 ²	1,0	5,9	2,3	93,4	89	78	6780
168.	Sh 500H8Ds	900	1210	746	11521	96,1	96,7	96,7	0,81	-	-	963 ²	1,0	6,1	2,3	103,0	89	78	7100
169.	Sh 500H8Es	1000	1350	745	12819	96,2	96,7	96,7	0,81	-	-	1081 ²	1,0	6,4	2,2	110,0	89	78	7400

¹ insulation class H

² at rated voltage 690 V

Totally Enclosed Motors IP 55

Item	Type	Rated output		Rated speed	Rated torque	Efficiency			Power factor	Full load current			Locked rotor torque	Locked rotor current	Breakdown torque	Moment of inertia	Sound power level		Sound pressure level	Weight (IMB3)
		P _N	η _N			T _N	N [%] at % of full load			I _N at rated voltage							L _{WA}	L _{PA}		
		[kW]	[HP]	[min ⁻¹]	[Nm]	50%	75%	100%	cos φ _N	I _N at rated voltage			[-]	[-]	[-]	J	[dB]	[dB]	m	
2p=10 n_s=600 rpm																				
170.	Sg 200L10A	7,5	10	580	123	82,5	84	85	0,68	-	19,7	18,7	1,7	3,5	2,1	0,4	73	63	240	
171.	Sg 200L10B	11	15	590	178	84,7	86,7	87,5	0,68	-	28,1	26,7	3,2	5,9	2,4	0,47	73	63	255	
172.	Sg 225S10	13	18	580	214	83,5	85	86	0,68	-	33,8	32,1	1,8	3,8	2	0,6	73	63	305	
173.	Sg 225M10	15	20	590	243	86	88	89	0,67	-	38,2	36,3	2,8	5,4	2	0,76	73	63	325	
174.	Sg 225M10z	18,5	25	590	300	84,3	87,1	87,7	0,64	-	50	47,5	2,8	5,5	2,1	0,76	73	63	325	
175.	Sg 250M10	22	30	592	352	87,5	89,6	90	0,70	-	53	50,3	3	5,8	2	1,27	78	68	450	
176.	Sg 280S10A	30	40	585	490	85,5	87,5	89	0,71	-	72	68,4	2	4,5	1,7	1,35	80	70	490	
177.	Sg 280S10B	37	50	588	601	87	90	91	0,74	-	83	79	1,9	4,5	1,5	1,61	80	70	520	
178.	Sg 280M10	45	60	587	732	88	90,5	91,6	0,76	-	98	93	2	4,5	1,6	2,03	80	70	570	
179.	Sg 315S10	45	60	588	731	90	91,5	92,1	0,71	-	105	99	2	4,1	2	2,16	80	70	720	
180.	Sg 315S10z	55	75	583	901	88	90,5	91,5	0,75	-	122	116	1,7	4,7	1,9	2,86	80	70	840	
181.	Sg 315M10	75	100	583	1229	88	90,5	91,5	0,75	-	166	158	1,8	4,9	1,5	3,01	80	70	895	
182.	Sg 355S10	75	100	592	1211	92,3	93,5	93,3	0,77	-	-	151	1,4	6,0	2,4	8,2	86	75	1150	
183.	Sg 355S10A	90	125	592	1453	93,1	94,1	94	0,81	-	-	176	1,4	5,7	2,2	8,2	94	75	1250	
184.	Sg 355S10B	110	150	592	1775	93,8	94,6	94,4	0,79	-	-	213	1,4	5,8	2,4	10,3	85	75	1390	
185.	Sg 355M10A	132	175	592	2131	93,9	94,6	94,4	0,8	-	-	253	1,8	6,1	2,3	12,7	87	77	1620	
186.	Sg 355M10B	160	220	592	2582	93,7	94,7	94,7	0,83	-	-	294	1,8	6,3	2,4	14,1	87	77	1730	
187.	Sh 450H10As	315	430	594	5064	94,9	95,5	95,5	0,81	-	-	341 ¹	1,0	5,9	2,2	49,4	89	78	4050	
188.	Sh 450H10Bs	355	480	594	5707	95,0	95,7	95,7	0,81	-	-	384 ¹	1,0	6,0	2,3	53,9	89	78	4130	
189.	Sh 450H10Cs	400	540	594	6431	95,0	95,7	95,7	0,81	-	-	432 ¹	1,1	6,4	2,3	58,3	89	78	4300	
190.	Sh 500H10As	450	610	594	7235	95,1	95,8	95,7	0,81	-	-	486 ¹	1,4	6,3	2,1	74,1	90	78	5420	
191.	Sh 500H10Bs	500	680	594	8039	95,2	95,9	95,8	0,82	-	-	533 ¹	1,5	6,6	2,2	85,5	90	78	5700	
192.	Sh 500H10Cs	560	760	593	9018	95,4	95,9	95,8	0,82	-	-	597 ¹	1,3	6,2	2,0	94,2	90	78	5950	
193.	Sh 500H10Ds	630	850	594	10129	95,5	96,0	96,0	0,82	-	-	670 ¹	1,7	6,9	2,2	108	90	78	6400	
2p=12 n_s=500 rpm																				
194.	Sg 200L12	9	12	490	175	75,3	80,1	81,8	0,55	-	30,5	28,9	2,7	4,3	2,5	0,47	75	64	255	
195.	Sg 200L12z	11	15	487	216	81	82	82,5	0,58	-	34,9	33,2	2,5	4,2	1,9	0,53	77	66	320	
196.	Sg 225S12	11	15	475	221	80,7	82,2	82	0,59	-	34,5	32,8	1,7	3,5	1,7	0,58	80	70	320	
197.	Sg 225M12	13	18	475	261	81,5	82,2	82,5	0,59	-	40,5	38,6	1,7	3,5	1,7	0,68	80	70	350	
198.	Sg 250M12	18,5	25	480	368	83	85	84,5	0,59	-	56	54	1,7	3,5	1,8	1,27	80	70	450	
199.	Sg 280S12	22	30	491	428	86,9	89,2	89,6	0,61	-	61	58	2,3	4,5	1,8	1,47	81	71	520	
200.	Sg 280M12	30	40	485	591	85	87	87,5	0,62	-	84	80	1,8	3,5	1,8	1,8	81	71	570	
201.	Sg 315S12	37	50	492	718	87,5	89,9	90,4	0,58	-	107	102	2,6	4,5	1,9	2,29	82	72	720	
202.	Sg 315M12A	45	60	490	877	87,1	89,3	89	0,58	-	132	126	2	3,5	1,8	2,86	82	72	850	
203.	Sg 315M12B	55	75	490	1072	87,5	90	89,5	0,59	-	158	150	2,5	4,4	1,8	3,01	82	72	885	
204.	Sg 355S12	75	100	492	1456	91,2	92,6	92,5	0,75	-	-	157	1,2	4,3	1,9	8,3	86	75	1250	
205.	Sg 355S12A	90	125	493	1743	92,5	93,6	93,4	0,72	-	-	193	1,2	5,6	2,2	10,4	86	75	1390	
206.	Sg 355S12B	110	150	491	2141	92,6	93,7	93,5	0,76	-	-	224	1,5	5,1	1,9	12,1	87	76	1570	
207.	Sg 355M12	132	175	492	2564	92,4	93,8	94,2	0,74	-	-	273	1,2	4,8	1,9	13,1	89	77	1730	

¹ - at rated voltage 690 V

FOOT MOUNTED MOTORS - IM B3



DIMENSION DRAWINGS

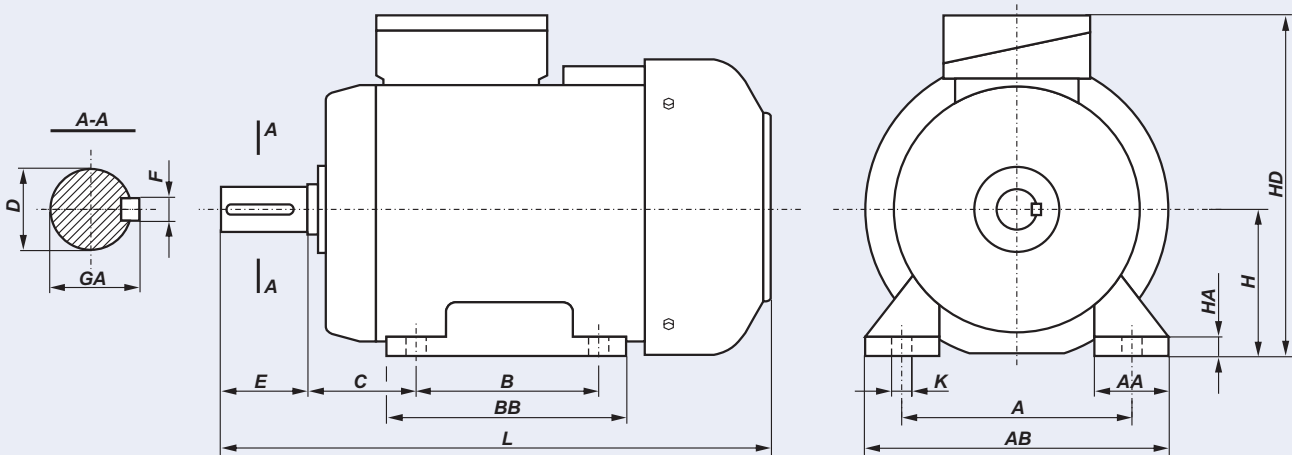

Motor type	A	B	C	D	E	F	GA	H	HA	K	AA	AB	BB	HD	L
Sg 56-2A	90	71	36	9j6	20	3h9	10,2	56	7	5,8	30	110	92	154	188
Sg 56-4A	90	71	36	9j6	20	3h9	10,2	56	7	5,8	30	110	92	154	149 *
Sg 56-2B	90	71	36	9j6	20	3h9	10,2	56	7	5,8	30	110	92	154	196
Sg 56-4B	90	71	36	9j6	20	3h9	10,2	56	7	5,8	30	110	92	154	157 *
Sg 56-6B	90	71	36	9j6	20	3h9	10,2	56	7	5,8	30	110	92	154	196
Sg 63-A	100	80	40	11j6	23	4h9	12,5	63	8,5	7	36	124	106	165	201
Sg 63-B	100	80	40	11j6	23	4h9	12,5	63	8,5	7	36	124	106	165	213
Sh 71-A	112	90	45	14j6	30	5h9	16	71	8	7	45	142	116	182	223
Sh 71-B	112	90	45	14j6	30	5h9	16	71	8	7	45	142	116	182	245
Sh 80-A	125	100	50	19j6	40	6h9	21,5	80	9	10	55	160	130	200	266
Sh 80-B	125	100	50	19j6	40	6h9	21,5	80	9	10	55	160	130	200	278
Sh 90S ...	140	100	56	24j6	50	8h9	27	90	10	10	50	170	153	220	305
Sh 90L ...	140	125	56	24j6	50	8h9	27	90	10	10	50	170	153	220	330
Sg 100L ...	160	140	63	28j6	60	8h9	31	100	14	12	45	200	172	240	376
Sg 112M ...	190	140	70	28j6	60	8h9	31	112	14	12	54	230	174	276	384
Sg 132S ...	216	140	89	38k6	80	10h9	41	132	16	12	56	278	182	310	463
Sg 132S-2B	216	140	89	38k6	80	10h9	41	132	16	12	56	278	220	310	501
Sg 132M ...	216	178	89	38k6	80	10h9	41	132	16	12	56	278	220	310	501
Sg 160M ...	254	210	108	42k6	110	12h9	45	160	20	15	60	305	256	370	612
Sg 160L ...	254	254	108	42k6	110	12h9	45	160	20	15	60	305	300	370	656
Sg 180M ...	279	241	121	48k6	110	14h9	51,5	180	26	15	70	350	320	408	705
Sg 180L ...	279	279	121	48k6	110	14h9	51,5	180	26	15	70	350	320	408	705

* - the Sg 56-4A and 4B motors in their standard version have neither fan nor fan cover.

FOOT MOUNTED MOTORS - IM B3

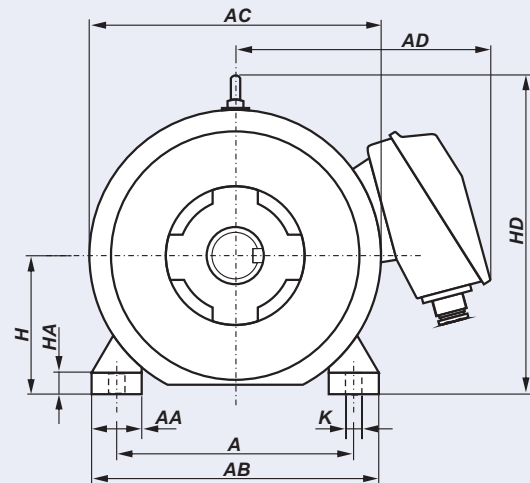
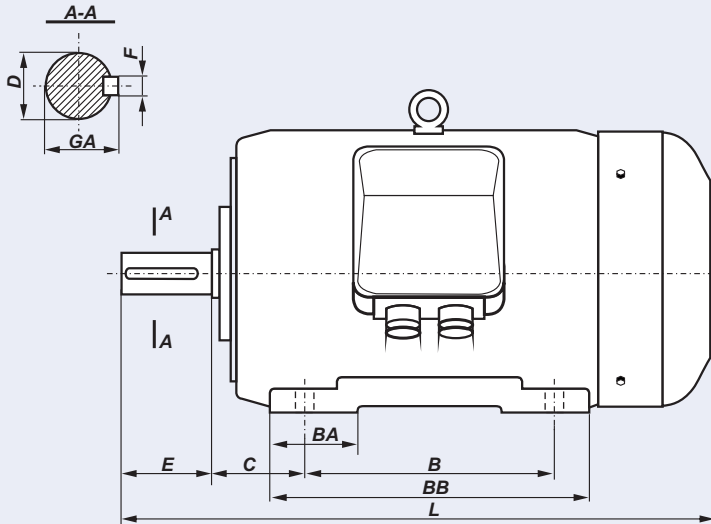

Motor type	A	B	C	D	E	F	GA	H	HA	K	AA	AB	AC	AD	BA	BB	HD	L
Sg 200 L..	318	305	133	55m6	110	16h9	59	200	32	19	80	400	450	355	100	380	485	825
Sg 225 S..	356	286	149	60m6	140	18h9	64	225	34	19	85	445	505	375	110	355	535	865
Sg 225 M2	356	311	149	55m6	110	16h9	59	225	34	19	85	445	505	375	110	380	535	860
Sg 225 M..	356	311	149	60m6	140	18h9	64	225	34	19	85	445	505	375	110	380	535	890
Sg 250 M2	406	349	168	60m6	140	18h9	64	250	36	24	90	495	540	415	120	420	590	965
Sg 250 M..	406	349	168	65m6	140	18h9	69	250	36	24	90	495	540	415	120	420	590	965
Sg 280 S2	457	368	190	65m6	140	18h9	69	280	40	24	100	560	620	450	165	520	660	1040
Sg 280 S..	457	368	190	75m6	140	20h9	79,5	280	40	24	100	560	620	450	165	520	660	1040
Sg 280 M2	457	419	190	65m6	140	18h9	69	280	40	24	100	560	620	450	165	520	660	1040
Sg 280 M..	457	419	190	75m6	140	20h9	79,5	280	40	24	100	560	620	450	165	520	660	1040
Sg 315 S2	508	406	216	65m6	140	18h9	69	315	46	28	105	610	620	450	190	560	695	1180
Sg 315 S..	508	406	216	80m6	170	22h9	85	315	46	28	105	610	620	450	190	560	695	1210
Sg 315 M2	508	457	216	65m6	140	18h9	69	315	46	28	105	610	620	450	190	560	695	1180
Sg 315 M..	508	457	216	80m6	170	22h9	85	315	46	28	105	610	620	450	190	560	695	1210
Sg 315 M.C	508	457	216	80m6	170	22h9	85	315	45	28	134	640	694	598	150	550	750	1240
Sg 355 S2	610	500	254	80m6	170	22h9	85	355	50	28	158	720	764	620	170	600	848	1354
Sg 355 S..	610	500	254	100m6	210	28h9	106	355	50	28	158	720	764	620	170	600	848	1394
Sg 355 M..	610	560	254	100m6	210	28h9	106	355	50	28	158	720	764	620	205	730	848	1454

DIMENSION DRAWINGS

FOOT MOUNTED MOTORS - IM B3

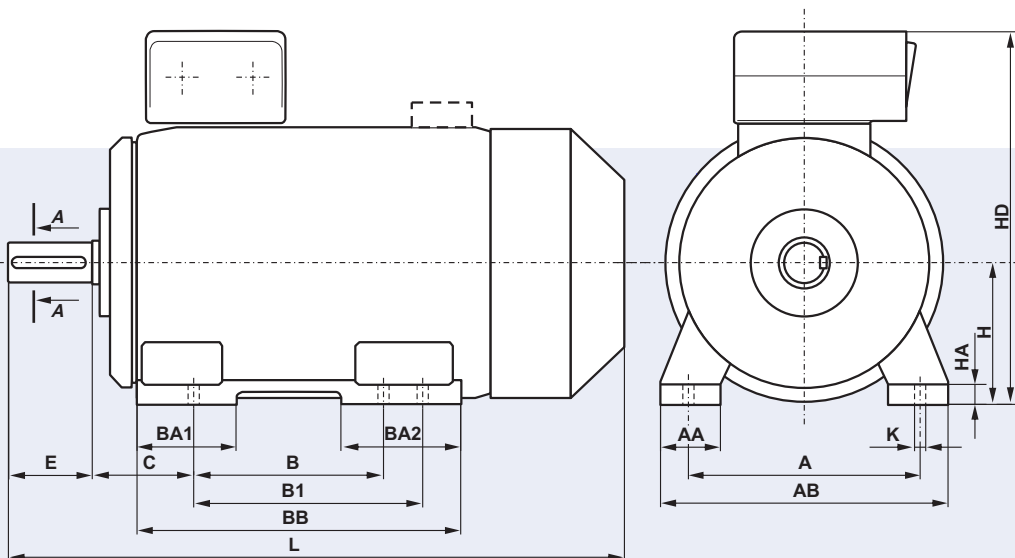
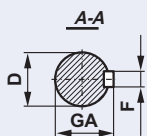
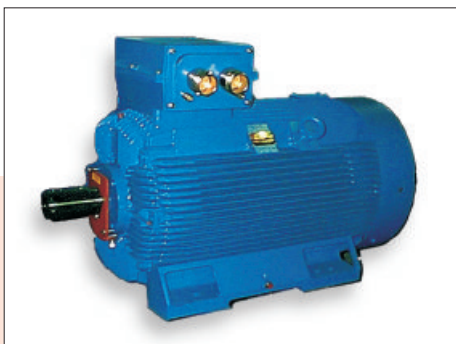

Motor type	Poles	Dimensions (mm)																		
		A	B	B1	C	D	E	F	GA	H	HA	K	AA	AB	BA1	BA2	BB	HD	L	
SEE 315M..	2	508	457	508	216	65	140	18	69	315	46	28	120	610	117	168	550	805	1225	
SEE 315M..	4	508	457	508	216	80	170	22	85	315	46	28	120	610	117	168	550	805	1200	
SEE 315M6C	6	508	457	508	216	80	170	22	85	315	46	28	120	610	117	168	550	805	1200	
SEE 315M6D	6	508	457	508	216	90	170	25	95	315	46	28	120	610	117	168	550	805	1255	
SEE 315M..	8	508	457	-	216	90	170	25	95	315	46	28	120	610	117	168	550	805	1255	
SEE 355....	2	610	560	630	254	80	170	22	85	355	50	28	150	720	250	300	890	935	1580	
SEE 355....	4÷8	610	560	630	254	100	210	28	106	355	50	28	150	720	250	300	890	935	1620	
Sh 355...s	2	610	900	-	200	70	140	20	75	355	45	28	160	730	265	265	1045	995	1800	
Sh 355...s	4÷8	610	900	-	200	100	210	28	106	355	45	28	160	730	265	265	1045	995	1870	

DIMENSION DRAWINGS

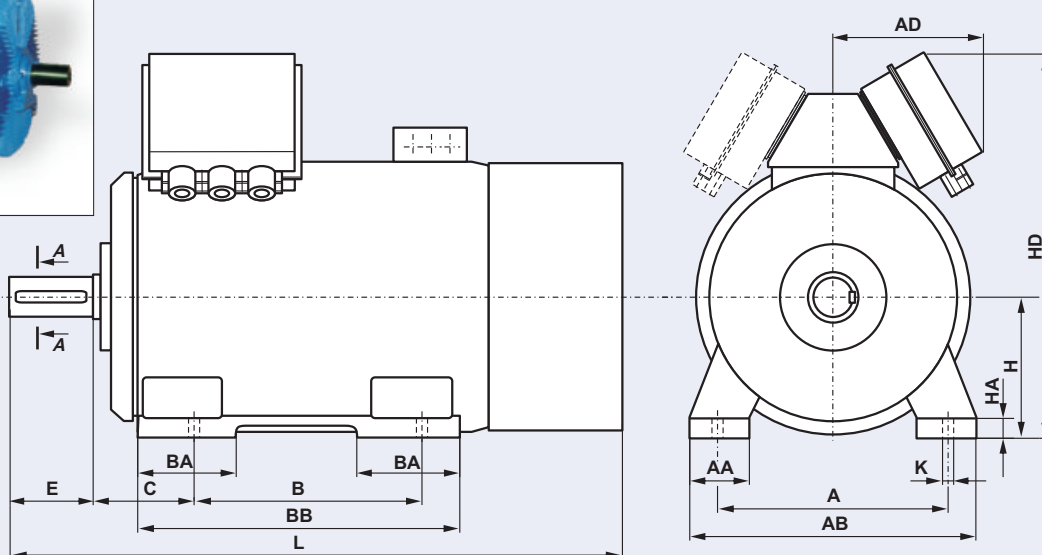
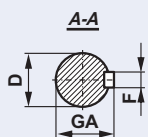

Motor type	Poles	Dimensions (mm)																
		A	B	C	D	E	F	GA	H	HA	K	AA	AB	AD	BA	BB	HD	L
Sh 400...s	2	686	1000	224	80	170	22	85	400	50	35	175	840	520	265	1160	1255	1980
Sh 400...s	4÷8	686	1000	224	110	210	28	116	400	50	35	175	840	520	265	1160	1255	1960
Sh 450...s	4÷12	750	1120	254	110	210	28	116	450	60	35	205	940	560	340	1320	1356	2105
Sh 500...s	4÷10	850	1250	280	120	210	32	127	500	70	42	223	1050	560	300	1450	1470	2430

FOOT/FLANGE MOUNTED MOTORS - IM B35

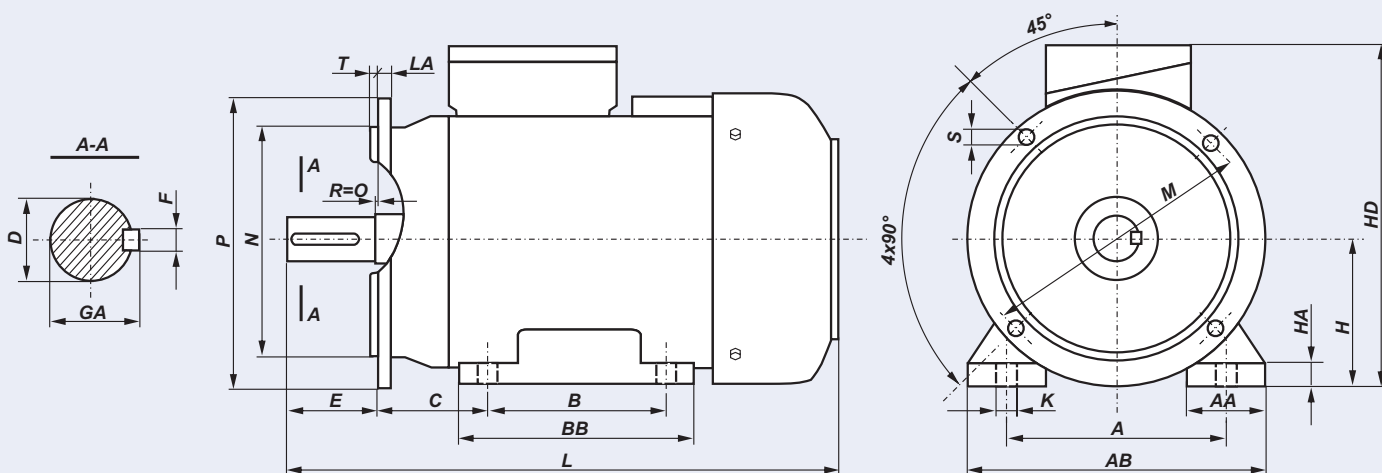

DIMENSION DRAWINGS

Motor type	A	B	C	D	E	F	GA	H	HA	K	AA	AB	BB	HD	L	LA	M	N	P	T	S
SLg 56-2A	90	71	36	9j6	20	3h9	10,2	56	7	8	30	110	92	154	188	8	100	80j6	120	3	7
SLg 56-4A	90	71	36	9j6	20	3h9	10,2	56	7	8	30	110	92	154	149	8	100	80j6	120	3	7
SLg 56-2B	90	71	36	9j6	20	3h9	10,2	56	7	8	30	110	92	154	196	8	100	80j6	120	3	7
SLg 56-4B	90	71	36	9j6	20	3h9	10,2	56	7	8	30	110	92	154	157	8	100	80j6	120	3	7
SLg 56-6B	90	71	36	9j6	20	3h9	10,2	56	7	8	30	110	92	154	196	8	100	80j6	120	3	7
SLg 63- A	100	80	40	11j6	23	4h9	12,5	63	8,5	10	36	124	106	165	201	9	115	95j6	140	3	10
SLg 63- B	100	80	40	11j6	23	4h9	12,5	63	8,5	10	36	124	106	165	213	9	115	95j6	140	3	10
SLh 71- A	112	90	45	14j6	30	5h9	16	71	8	10	45	142	116	182	223	9	130	110j6	160	3,5	10
SLh 71- B	112	90	45	14j6	30	5h9	16	71	8	10	45	142	116	182	245	9	130	110j6	160	3,5	10
SLh 80- A	125	100	50	19j6	40	6h9	21,5	80	9	10	55	160	130	200	266	10	165	130j6	200	3,5	12
SLh 80- B	125	100	50	19j6	40	6h9	21,5	80	9	10	55	160	130	200	278	10	165	130j6	200	3,5	12
SLh 90S ...	140	100	56	24j6	50	8h9	27	90	10	10	50	170	153	220	305	8	165	130j6	200	3,5	12
SLh 90L ...	140	125	56	24j6	50	8h9	27	90	10	10	50	170	153	220	330	8	165	130j6	200	3,5	12
SLg 100L ...	160	140	63	28j6	60	8h9	31	100	14	12	45	200	172	240	376	11	215	180j6	250	4	15
SLg 112M ...	190	140	70	28j6	60	8h9	31	112	14	12	54	230	174	276	384	12	215	180j6	250	4	15
SLg 132S ...	216	140	89	38k6	80	10h9	41	132	16	12	56	278	182	310	463	12	265	230j6	300	4	15
SLg 132S-2B	216	140	89	38k6	80	10h9	41	132	16	12	56	278	220	310	501	12	265	230j6	300	4	15
SLg 132M ...	216	178	89	38k6	80	10h9	41	132	16	12	56	278	220	310	501	12	265	230j6	300	4	15
SLg 160M ...	254	210	108	42k6	110	12h9	45	160	20	15	60	305	256	370	612	13	300	250j6	350	5	19
SLg 160L ...	254	254	108	42k6	110	12h9	45	160	20	15	60	305	300	370	656	13	300	250j6	350	5	19
SLg 180M ...	279	241	121	48k6	110	14h9	51,5	180	26	15	70	350	320	408	705	13	300	250j6	350	5	19
SLg 180L ...	279	279	121	48k6	110	14h9	51,5	180	26	15	70	350	320	408	705	13	300	250j6	350	5	19

FOOT/FLANGE MOUNTED MOTORS - IM B35

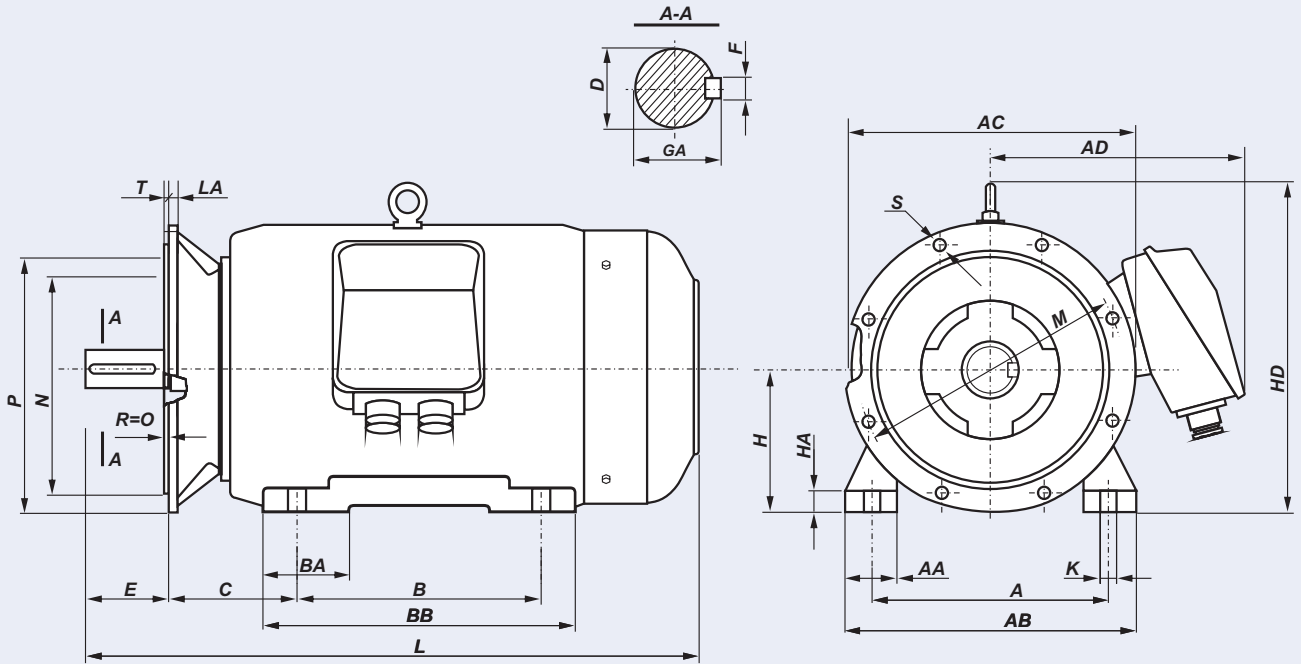
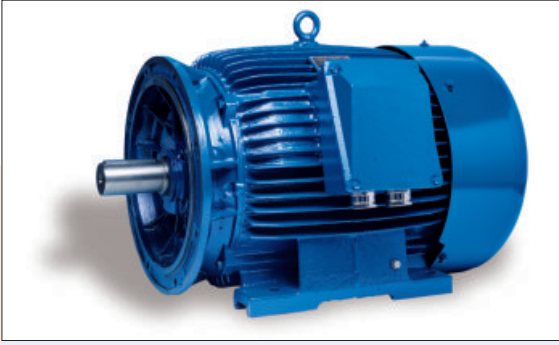

DIMENSION DRAWINGS

Motor type	A	B	C	D	E	F	GA	H	HA	K	AA	AB	AC	AD	BA	BB	HD	L	LA	M	N	P	T	S	ϕ	Holes
SLg 200 L..	318	305	133	55m6	110	16h9	59	200	32	19	80	400	450	355	100	380	485	825	16,5	350	300	400	5	18	4	
SLg 225 S..	356	286	149	60m6	140	18h9	64	225	34	19	85	445	505	375	110	355	535	870	18	400	350	450	5	18	8	
SLg 225 M2	356	311	149	55m6	110	16h9	59	225	34	19	85	445	505	375	110	380	535	865	18	400	350	450	5	18	8	
SLg 225 M..	356	311	149	60m6	140	18h9	64	225	34	19	85	445	505	375	110	380	535	895	18	400	350	450	5	18	8	
SLg 250 M2	406	349	168	60m6	140	18h9	64	250	36	24	90	495	540	415	120	420	590	965	19	500	450	550	5	18	8	
SLg 250 M..	406	349	168	65m6	140	18h9	69	250	36	24	90	495	540	415	120	420	590	965	19	500	450	550	5	18	8	
SLg 280 S2	457	368	190	65m6	140	18h9	69	280	40	24	100	560	620	450	165	520	660	1040	20	500	450	550	5	18	8	
SLg 280 S..	457	368	190	75m6	140	20h9	79,5	280	40	24	100	560	620	450	165	520	660	1040	20	500	450	550	5	18	8	
SLg 280 M2	457	419	190	65m6	140	18h9	69	280	40	24	100	560	620	450	165	520	660	1040	20	500	450	550	5	18	8	
SLg 280 M..	457	419	190	75m6	140	20h9	79,5	280	40	24	100	560	620	450	165	520	660	1040	20	500	450	550	5	18	8	
SLg 315 S2	508	406	216	65m6	140	18h9	69	315	46	28	105	610	620	450	190	560	695	1180	22	600	550	660	6	22	8	
SLg 315 S..	508	406	216	80m6	170	22h9	85	315	46	28	105	610	620	450	190	560	695	1210	22	600	550	660	6	22	8	
SLg 315 M2	508	457	216	65m6	140	18h9	69	315	46	28	105	610	620	450	190	560	695	1180	22	600	550	660	6	22	8	
SLg 315 M..	508	457	216	80m6	170	22h9	85	315	46	28	105	610	620	450	190	560	695	1210	22	600	550	660	6	22	8	
SLg 355 S2	610	500	254	80m6	170	22h9	85	355	50	28	158	720	764	620	170	600	848	1354	24	740	680	800	6	24	8	
SLg 355 S..	610	500	254	100m6	210	28h9	106	355	50	28	158	720	764	620	170	600	848	1394	24	740	680	800	6	24	8	
SLg 355 M..	610	560	254	100m6	210	28h9	106	355	50	28	158	720	764	620	205	730	848	1454	24	740	680	800	6	24	8	

FOOT/FLANGE MOUNTED MOTORS - IM B35

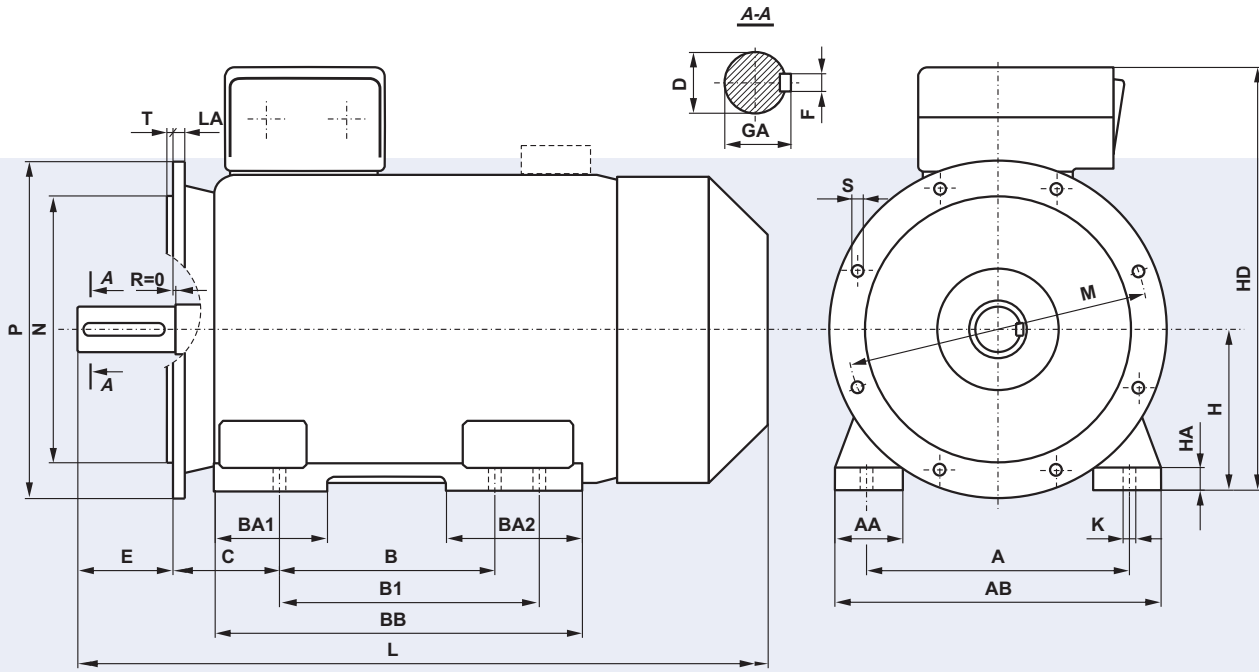

Type of motor	Poles	Dimensions (mm)																							
		A	B	B1	C	D	E	F	GA	H	HA	K	AA	AB	BA1	BA2	BB	HD	L	LA	M	N	P	S	T
SLEE 315M..	2	508	457	-	216	65	140	18	69	315	46	28	120	610	117	168	550	805	1225	22	600	550	660	22	6
SLEE 315M..	4	508	457	-	216	80	170	22	85	315	46	28	120	610	117	168	550	805	1200	22	600	550	660	22	6
SLEE 315M6C	6	508	457	-	216	80	170	22	85	315	46	28	120	610	117	168	550	805	1200	22	600	550	660	22	6
SLEE 315M6D	6	508	457	-	216	90	170	25	95	315	46	28	120	610	117	168	550	805	1255	22	600	550	660	22	6
SLEE 315M.	8	508	457	-	216	90	170	25	95	315	46	28	120	610	117	168	550	805	1255	22	600	550	660	22	6
SLEE 355....	2	610	560	630	254	80	170	22	85	355	50	28	150	720	250	300	890	935	1580	24	740	680	800	22	6
SLEE 355....	4+8	610	560	630	254	100	210	28	106	355	50	28	150	720	250	300	890	935	1620	24	740	680	800	22	6
SLh 355...s	2	610	900	-	254	70	140	20	74,5	355	45	28	160	730	265	265	1045	995	1854	24	740	680	800	22	6
SLh 355...s	4+8	610	900	-	254	100	210	28	106	355	45	28	160	730	265	265	1045	995	1924	24	740	680	800	22	6

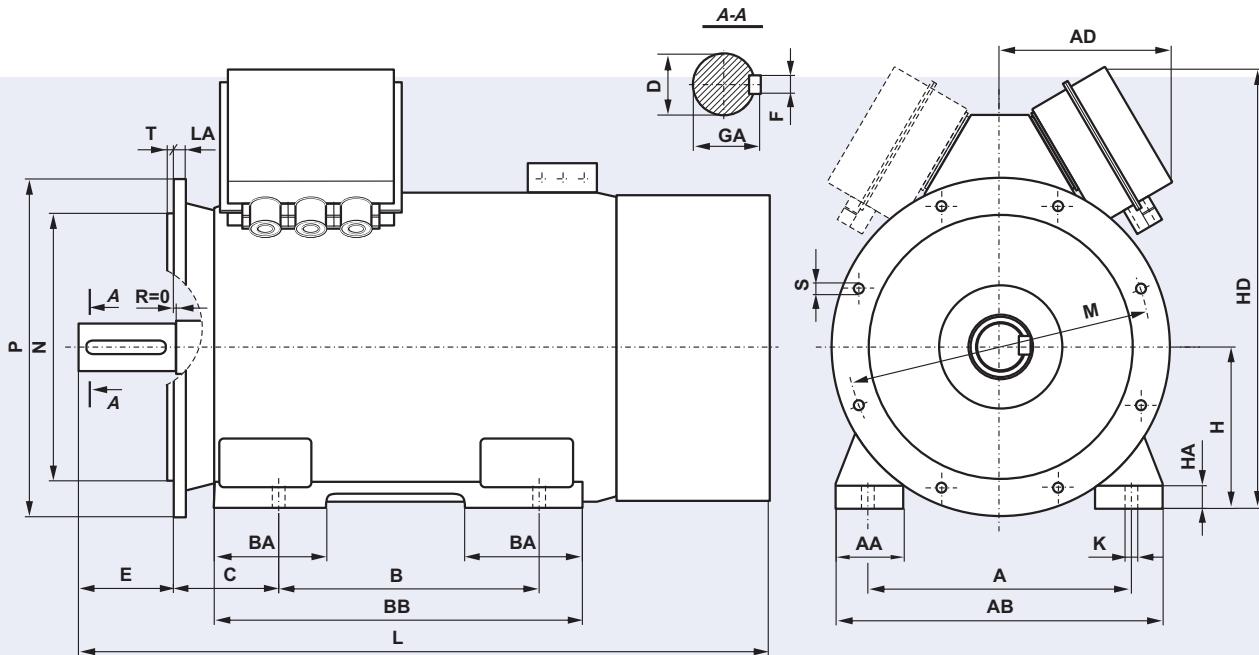

Type of motor	Poles	Dimensions (mm)																						
		A	B	C	D	E	F	GA	H	HA	K	AA	AB	AD	BA	BB	HD	L	LA	M	N	P	S	T
SLh 400...s	2	686	1000	280	80	170	22	85	400	50	35	175	840	520	265	1160	1255	2031	30	940	880	1000	25	6
SLh 400...s	4+8	686	1000	280	110	210	28	116	400	50	35	175	840	520	265	1160	1255	2016	30	940	880	1000	25	6
SLh 450...s	4+12	750	1120	315	110	210	28	116	450	60	35	205	940	560	340	1320	1356	2162	30	1080	1000	1150	28	6
SLh 500...s	4+10	850	1250	355	120	210	32	127	500	70	42	223	1050	560	300	1450	1470	2505	30	1080	1000	1150	28	6

DIMENSION DRAWINGS

FOOT/FLANGE MOUNTED MOTORS - IM B34

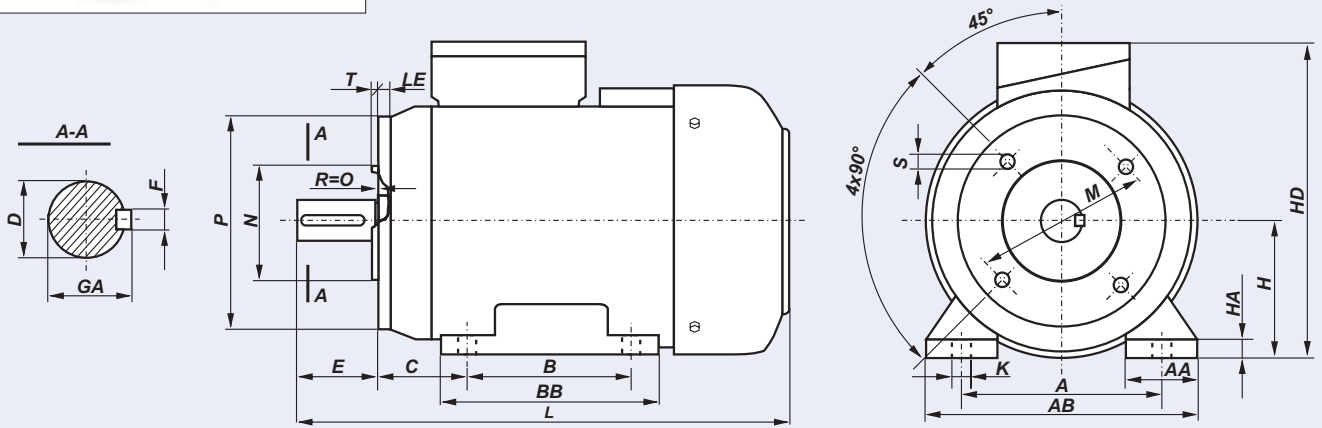

DIMENSION DRAWINGS

Motor type	Flange	A	AA	B	C	D	E	F	GA	H	HA	K	M	N	P	S	LE	T	HD	L
SLg 56-2A1	B14/C1	90	30	71	36	9j6	20	3h9	10,2	56	7	8	85	70j6	105	M6	15	2,5	154	188
SLg 56-2A2	B14/C2	90	30	71	36	9j6	20	3h9	10,2	56	7	8	65	50j6	80	M5	12,5	2,5	154	188
SLg 56-4A1	B14/C1	90	30	71	36	9j6	20	3h9	10,2	56	7	8	85	70j6	105	M6	15	2,5	154	149*
SLg 56-4A2	B14/C2	90	30	71	36	9j6	20	3h9	10,2	56	7	8	65	50j6	80	M5	12,5	2,5	154	149*
SLg 56-2B1	B14/C1	90	30	71	36	9j6	20	3h9	10,2	56	7	8	85	70j6	105	M6	15	2,5	154	196
SLg 56-2B2	B14/C2	90	30	71	36	9j6	20	3h9	10,2	56	7	8	65	50j6	80	M5	12,5	2,5	154	196
SLg 56-4B1	B14/C1	90	30	71	36	9j6	20	3h9	10,2	56	7	8	85	70j6	105	M6	15	2,5	154	157*
SLg 56-4B2	B14/C2	90	30	71	36	9j6	20	3h9	10,2	56	7	8	65	50j6	80	M5	12,5	2,5	154	157*
SLg 56-6B1	B14/C1	90	30	71	36	9j6	20	3h9	10,2	56	7	8	85	70j6	105	M6	15	2,5	154	196
SLg 56-6B2	B14/C2	90	30	71	36	9j6	20	3h9	10,2	56	7	8	65	50j6	80	M5	12,5	2,5	154	196
SLg 63- .A1	B14/C1	100	36	80	40	11j6	23	4h9	12,5	63	8,5	10	100	80j6	120	M6	14	3	165	201
SLg 63- .A2	B14/C2	100	36	80	40	11j6	23	4h9	12,5	63	8,5	10	75	60j6	90	M5	9,5	2,5	165	201
SLg 63- .B1	B14/C1	100	36	80	40	11j6	23	4h9	12,5	63	8,5	10	100	80j6	120	M6	14	3	165	213
SLg 63- .B2	B14/C2	100	36	80	40	11j6	23	4h9	12,5	63	8,5	10	75	60j6	90	M5	9,5	2,5	165	213
SLh 71- .A1	B14/C1	112	45	90	45	14j6	30	5h9	16	71	8	10	115	95j6	140	M8	14	3	182	223
SLh 71- .A2	B14/C2	112	45	90	45	14j6	30	5h9	16	71	8	10	85	70j6	105	M6	12	2,5	182	223
SLh 71- .B1	B14/C1	112	45	90	45	14j6	30	5h9	16	71	8	10	115	95j6	140	M8	14	3	182	245
SLh 71- .B2	B14/C2	112	45	90	45	14j6	30	5h9	16	71	8	10	85	70j6	105	M6	12	2,5	182	245
SLh 80- .A1	B14/C1	125	55	100	50	19j6	40	6h9	21,5	80	9	10	130	110j6	160	M8	14	3,5	200	266
SLh 80- .A2	B14/C2	125	55	100	50	19j6	40	6h9	21,5	80	9	10	100	80j6	120	M6	12	3	200	266
SLh 80- .B1	B14/C1	125	55	100	50	19j6	40	6h9	21,5	80	9	10	130	110j6	160	M8	14	3,5	200	278
SLh 80- .B2	B14/C2	125	55	100	50	19j6	40	6h9	21,5	80	9	10	100	80j6	120	M6	12	3	195	278
SLh 90S ...	B14/C1	140	50	100	56	24j6	50	8h9	27	90	10	10	130	110j6	160	M8	10	3,5	220	305
SLh 90S ...	B14/C2	140	50	100	56	24j6	50	8h9	27	90	10	10	115	95j6	140	M8	10	3	220	305
SLh 90L ...	B14/C1	140	50	125	56	24j6	50	8h9	27	90	10	10	130	110j6	160	M8	10	3,5	220	330
SLh 90L ...	B14/C2	140	50	125	56	24j6	50	8h9	27	90	10	10	115	95j6	140	M8	10	3	220	330
SLg 100L ...	B14/C1	160	45	140	63	28j6	60	8h9	31	100	14	12	165	130j6	200	M10	12	3,5	240	376
SLg 100L ...	B14/C2	160	45	140	63	28j6	60	8h9	31	100	14	12	130	110j6	160	M8	12	3,5	240	376
SLg 112M ...	B14/C1	190	54	140	70	28j6	60	8h9	31	112	14	12	165	130j6	200	M10	12	3,5	276	384
SLg 112M ...	B14/C2	190	54	140	70	28j6	60	8h9	31	112	14	12	130	110j6	160	M8	12	3,5	276	384
SLg 132S ...	B14/C1	216	56	140	89	38k6	80	10h9	41	132	16	12	215	180j6	250	M12	12	4	310	463
SLg 132S ...	B14/C2	216	56	140	89	38k6	80	10h9	41	132	16	12	165	130j6	200	M10	12	3,5	310	463
SLg 132S-2B	B14/C1	216	56	140	89	38k6	80	10h9	41	132	16	12	215	180j6	250	M12	12	4	310	501
SLg 132S-2B	B14/C2	216	56	140	89	38k6	80	10h9	41	132	16	12	165	130j6	200	M10	12	3,5	310	501
SLg 132M...	B14/C1	216	56	140	89	38k6	80	10h9	41	132	16	12	215	180j6	250	M12	12	4	310	501
SLg 132M...	B14/C2	216	56	140	89	38k6	80	10h9	41	132	16	12	165	130j6	200	M10	12	3,5	310	501

* - the SKg 56-4A and 4B motors in their standard version have neither fan nor fan cover.

General Purpose 3-Phase Induction Motors
FLANGE MOUNTED MOTORS - IM B5

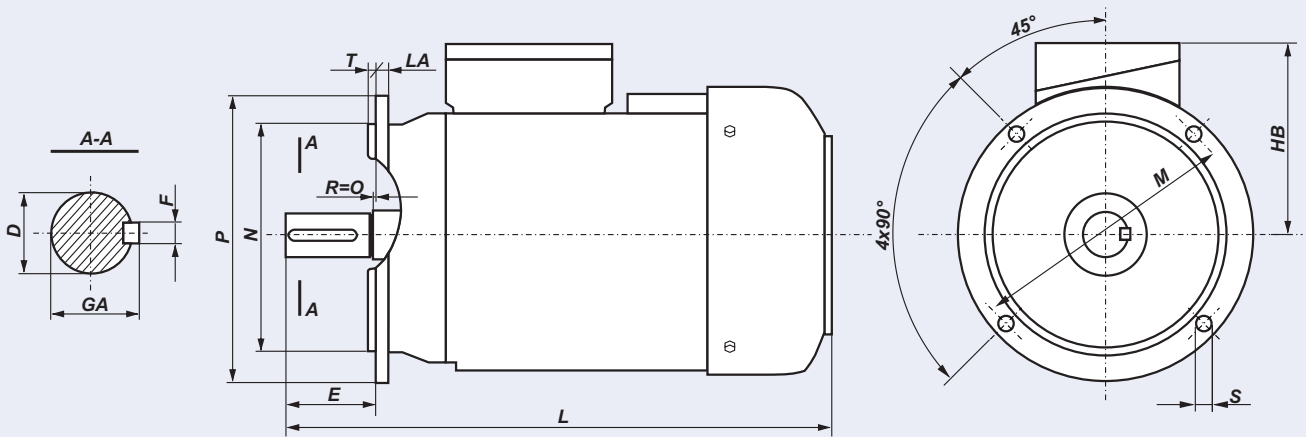

Type of motor	D	E	F	GA	M	N	P	LA	T	S	HB	L
SKg 56-2A	9j6	20	3h9	10,2	100	80j6	120	8	3	7	98	188
SKg 56-4A	9j6	20	3h9	10,2	100	80j6	120	8	3	7	98	149*
SKg 56-2B	9j6	20	3h9	10,2	100	80j6	120	8	3	7	98	196
SKg 56-4B	9j6	20	3h9	10,2	100	80j6	120	8	3	7	98	157*
SKg 56-6B	9j6	20	3h9	10,2	100	80j6	120	8	3	7	98	196
SKg 63- .A	11j6	23	4h9	12,5	115	95j6	140	9	3	10	102	201
SKg 63- .B	11j6	23	4h9	12,5	115	95j6	140	9	3	10	102	213
SKh 71- .A	14j6	30	5h9	16	130	110j6	160	9	3,5	10	111	223
SKh 71- .B	14j6	30	5h9	16	130	110j6	160	9	3,5	10	111	245
SKh 80- .A	19j6	40	6h9	21,5	165	130j6	200	10	3,5	12	115	266
SKh 80- .B	19j6	40	6h9	21,5	165	130j6	200	10	3,5	12	115	278
SKh 90S ...	24j6	50	8h9	27	165	130j6	200	8	3,5	12	130	305
SKh 90L ...	24j6	50	8h9	27	165	130j6	200	8	3,5	12	130	330
SKg 100L ...	28j6	60	8h9	31	215	180j6	250	11	4	15	140	376
SKg 112M ...	28j6	60	8h9	31	215	180j6	250	12	4	15	164	384
SKg 132S ...	38k6	80	10h9	41	265	230j6	300	12	4	15	178	463
SKg 132S-2B	38k6	80	10h9	41	265	230j6	300	12	4	15	178	501
SKg 132M ...	38k6	80	10h9	41	265	230j6	300	12	4	15	178	501
SKg 160M ...	42k6	110	12h9	45	300	250j6	350	13	5	19	210	612
SKg 160L ...	42k6	110	12h9	45	300	250j6	350	13	5	19	210	656
SKg 180M ...	48k6	110	14h9	51,5	300	250j6	350	13	5	19	228	705
SKg 180L ...	48k6	110	14h9	51,5	300	250j6	350	13	5	19	228	705

* - the SKg 56-4A and 4B motors in their standard version have neither fan nor fan cover

DIMENSION DRAWINGS

FLANGE MOUNTED MOTORS - IM B5, IM V1

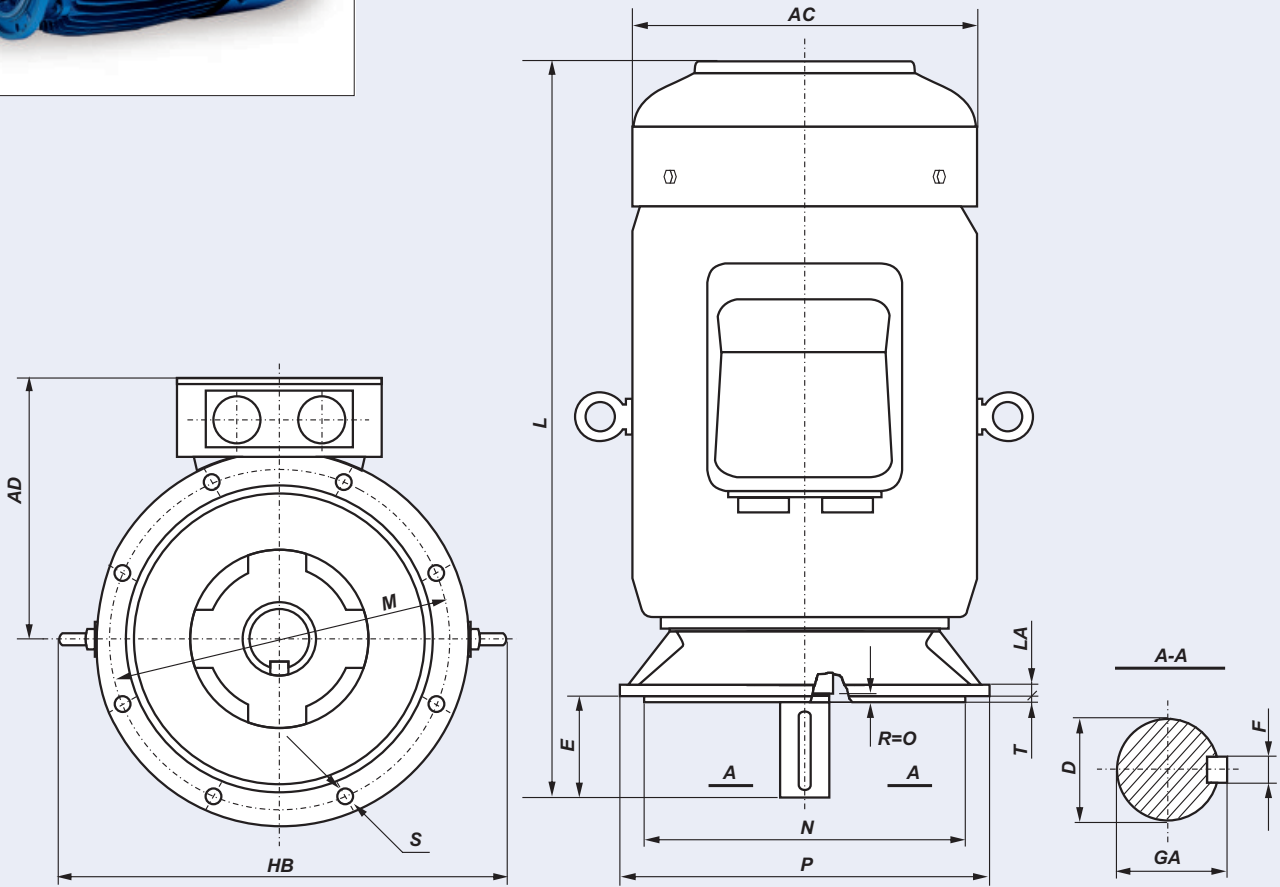

DIMENSION DRAWINGS

Motor type	D	E	F	GA	AC	AD	HB	L	LA	M	N	P	T	S	Holes
SKg 200 L...	55m6	110	16h9	59	450	355	570	825	16,5	350	300j6	400	5	18	4
SKg 225 S...	60m6	140	18h9	64	505	375	620	865	18	400	350j6	450	5	18	8
SKg 225 M2	55m6	110	16h9	59	505	375	620	860	18	400	350j6	450	5	18	8
SKg 225 M...	60m6	140	18h9	64	505	375	620	890	18	400	350j6	450	5	18	8
SKg 250 M2	60m6	140	18h9	64	540	415	675	965	19	500	450j6	550	5	18	8
SKg 250 M...	65m6	140	18h9	69	540	415	675	965	19	500	450j6	550	5	18	8
SKg 280 S2	65m6	140	18h9	69	620	450	755	1040	20	500	450j6	550	5	18	8
SKg 280 S...	75m6	140	20h9	79,5	620	450	755	1040	20	500	450j6	550	5	18	8
SKg 280 M2	65m6	140	18h9	69	620	450	755	1040	20	500	450j6	550	5	18	8
SKg 280 M...	75m6	140	20h9	79,5	620	450	755	1040	20	500	450j6	550	5	18	8
SKg 315 S2	65m6	140	18h9	69	620	450	790	1180	22	600	550j6	660	6	22	8
SKg 315 S...	80m6	170	22h9	85	620	450	790	1210	22	600	550j6	660	6	22	8
SKg 315 M2	65m6	140	18h9	69	620	450	790	1180	22	600	550j6	660	6	22	8
SKg 315 M...	80m6	170	22h9	85	620	450	790	1210	22	600	550j6	660	6	22	8
SVg 315 M.C *	80m6	170	22h9	85	693	551	877	1355	22	600	550js6	660	6	22	8
SVg 355 S.. *	100m6	210	28h9	106	767	588	970	1580	24	740	680js6	800	6	24	8
SVg 355 M.. *	100m6	210	28h9	106	767	588	970	1580	24	740	680js6	800	6	24	8

* - the SVg motors may operate only in vertical position IM V1.

FLANGE MOUNTED MOTORS - IM B5, IM V1

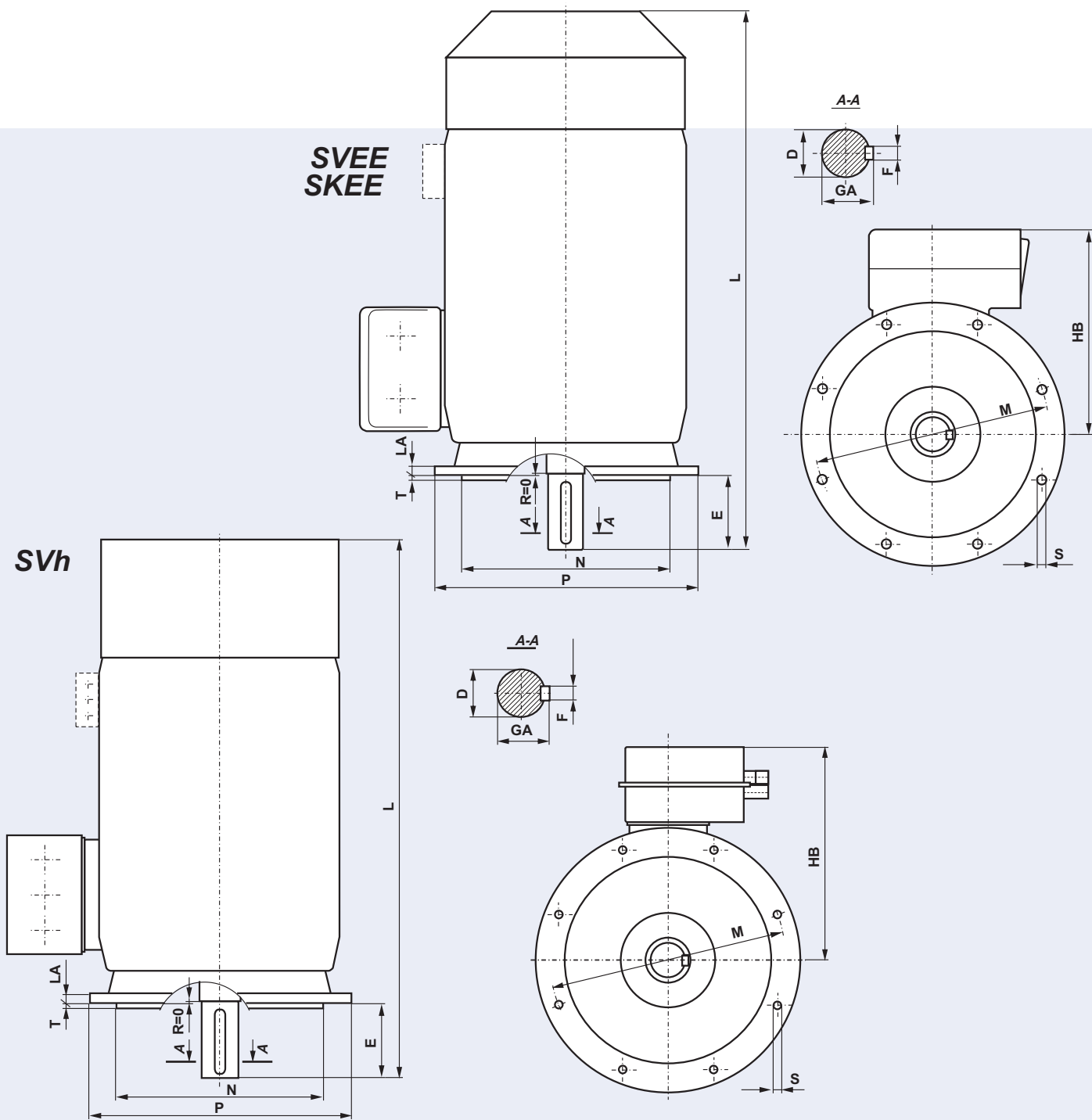

DIMENSION DRAWINGS

Motor type	Poles	D	E	F	GA	HB	L	LA	M	N	P	S	T
SKEE 315M..	2	65	140	18	69	490	1225	22	600	550	660	24	6
SKEE 315M..	4	80	170	22	85	490	1200	22	600	550	660	24	6
SKEE 315M6C	6	80	170	22	85	490	1200	22	600	550	660	24	6
SKEE 316M6D	6	90	170	25	95	490	1255	22	600	550	660	24	6
SKEE 315M..	8	90	170	25	95	490	1255	22	600	550	660	24	6
SVEE 355...*	4+8	100	210	28	106	580	1620	24	740	680	800	22	6
SVh 355...s*	4+8	100	210	28	106	640	1955	24	740	680	800	22	6
SVh 400...s*	4+8	110	210	28	116	725	2016	37	940	880	1000	23	6
SVh 450...s*	4+10	110	210	28	116	835	2162	30	1080	1000	1150	28	6
SVh 500...s*	4+10	120	210	32	127	835	2505	30	1080	1000	1150	28	6

* - the SVh and SVEE motors may operate only in vertical position IM V1.

FLANGE MOUNTED MOTORS - IM B14

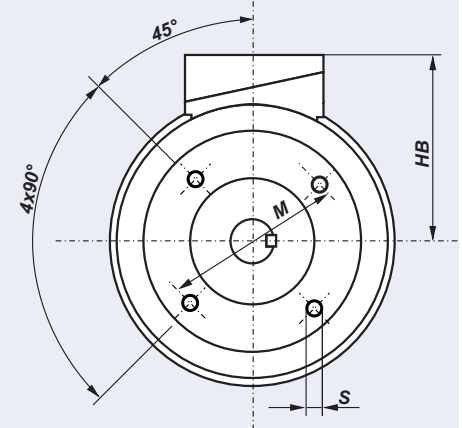
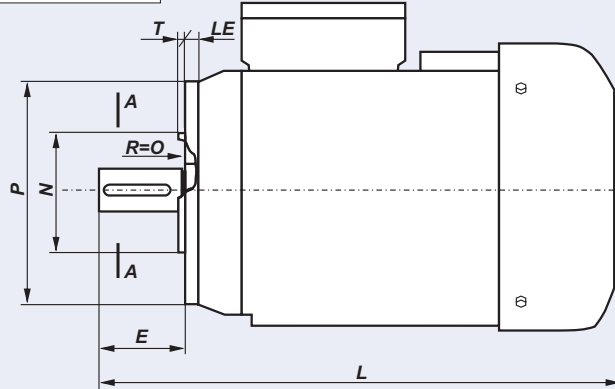
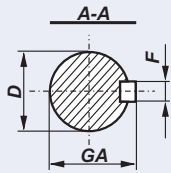

DIMENSION DRAWINGS

Motor type	Flange	D	E	F	GA	M	N	P	S	T	LE	HB	L
SKg 56-2A1	B14/C1	9j6	20	3h9	10,2	85	70j6	105	M6	2,5	15	98	188
SKg 56-2A2	B14/C2	9j6	20	3h9	10,2	65	50j6	80	M5	2,5	12,5	98	188
SKg 56-4A1	B14/C1	9j6	20	3h9	10,2	85	70j6	105	M6	2,5	15	98	149*
SKg 56-4A2	B14/C2	9j6	20	3h9	10,2	65	50j6	80	M5	2,5	12,5	98	149*
SKg 56-2B1	B14/C1	9j6	20	3h9	10,2	85	70j6	105	M6	2,5	15	98	196
SKg 56-2B2	B14/C2	9j6	20	3h9	10,2	65	50j6	80	M5	2,5	12,5	98	196
SKg 56-4B1	B14/C1	9j6	20	3h9	10,2	85	70j6	105	M6	2,5	15	98	157*
SKg 56-4B2	B14/C2	9j6	20	3h9	10,2	65	50j6	80	M5	2,5	12,5	98	157*
SKg 56-6B1	B14/C1	9j6	20	3h9	10,2	85	70j6	105	M6	2,5	15	98	196
SKg 56-6B2	B14/C2	9j6	20	3h9	10,2	65	50j6	80	M5	2,5	12,5	98	196
SKg 63- .A1	B14/C1	11j6	23	4h9	12,5	100	80j6	120	M6	3	14	102	201
SKg 63- .A2	B14/C2	11j6	23	4h9	12,5	75	60j6	90	M5	2,5	9,5	102	201
SKg 63- .B1	B14/C1	11j6	23	4h9	12,5	100	80j6	120	M6	3	14	102	213
SKg 63- .B2	B14/C2	11j6	23	4h9	12,5	75	60j6	90	M5	2,5	9,5	102	213
SKh 71- .A1	B14/C1	14j6	30	5h9	16	115	95j6	140	M8	3	14	111	223
SKh 71- .A2	B14/C2	14j6	30	5h9	16	85	70j6	105	M6	2,5	12	111	223
SKh 71- .B1	B14/C1	14j6	30	5h9	16	115	95j6	140	M8	3	14	111	245
SKh 71- .B2	B14/C2	14j6	30	5h9	16	85	70j6	105	M6	2,5	12	111	245
SKh 80- .A1	B14/C1	19j6	40	6h9	21,5	130	110j6	160	M8	3,5	14	115	266
SKh 80- .A2	B14/C2	19j6	40	6h9	21,5	100	80j6	120	M6	3	12	115	266
SKh 80- .B1	B14/C1	19j6	40	6h9	21,5	130	110j6	160	M8	3,5	14	115	278
SKh 80- .B2	B14/C2	19j6	40	6h9	21,5	100	80j6	120	M6	3	12	115	278
SKh 90S ...	B14/C1	24j6	50	8h9	27	130	110j6	160	M8	3,5	10	130	305
SKh 90S ...	B14/C2	24j6	50	8h9	27	115	95j6	140	M8	3	10	130	305
SKh 90L ...	B14/C1	24j6	50	8h9	27	130	110j6	160	M8	3,5	10	130	330
SKh 90L ...	B14/C2	24j6	50	8h9	27	115	95j6	140	M8	3	10	130	330
SKg 100L ...	B14/C1	28j6	60	8h9	31	165	130j6	200	M10	3,5	12	140	376
SKg 100L ...	B14/C2	28j6	60	8h9	31	130	110j6	160	M8	3,5	12	140	376
SKg 112M ...	B14/C1	28j6	60	8h9	31	165	130j6	200	M10	3,5	12	164	384
SKg 112M ...	B14/C2	28j6	60	8h9	31	130	110j6	160	M8	3,5	12	164	384
SKg 132S ...	B14/C1	38k6	80	10h9	41	215	180j6	250	M12	4	12	178	463
SKg 132S ...	B14/C2	38k6	80	10h9	41	165	130j6	200	M10	3,5	12	178	463
SKg 132S-2B	B14/C1	38k6	80	10h9	41	215	180j6	250	M12	4	12	178	501
SKg 132S-2B	B14/C2	38k6	80	10h9	41	165	130j6	200	M10	3,5	12	178	501
SKg 132M ...	B14/C1	38k6	80	10h9	41	215	180j6	250	M12	4	12	178	501
SKg 132M ...	B14/C2	38k6	80	10h9	41	165	130j6	200	M10	3,5	12	178	501

* - the SKg 56-4A and 4B motors in their standard version have neither fan nor fan cover.

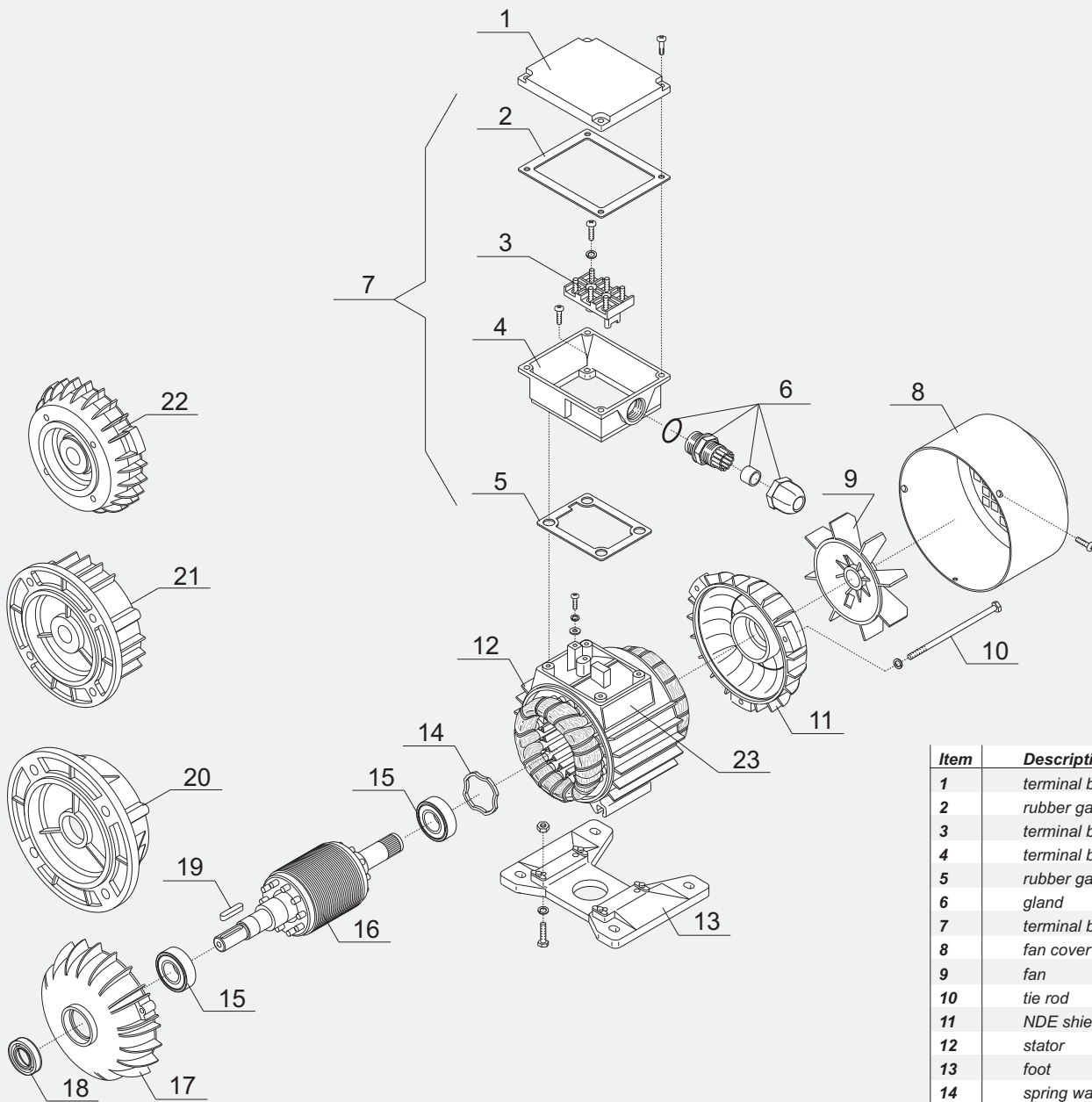

Item	Description
1	terminal box cover
2	rubber gasket
3	terminal board
4	terminal box
5	rubber gasket
6	gland
7	terminal box complete
8	fan cover
9	fan
10	tie rod
11	NDE shield
12	stator
13	foot
14	spring washer
15	bearing
16	rotor
17	DE shield
18	shaft seal
19	key
20	flange B5
21	flange B14/C1
22	flange B14/C2
23	name plate

DE - drive end
NDE - non drive end

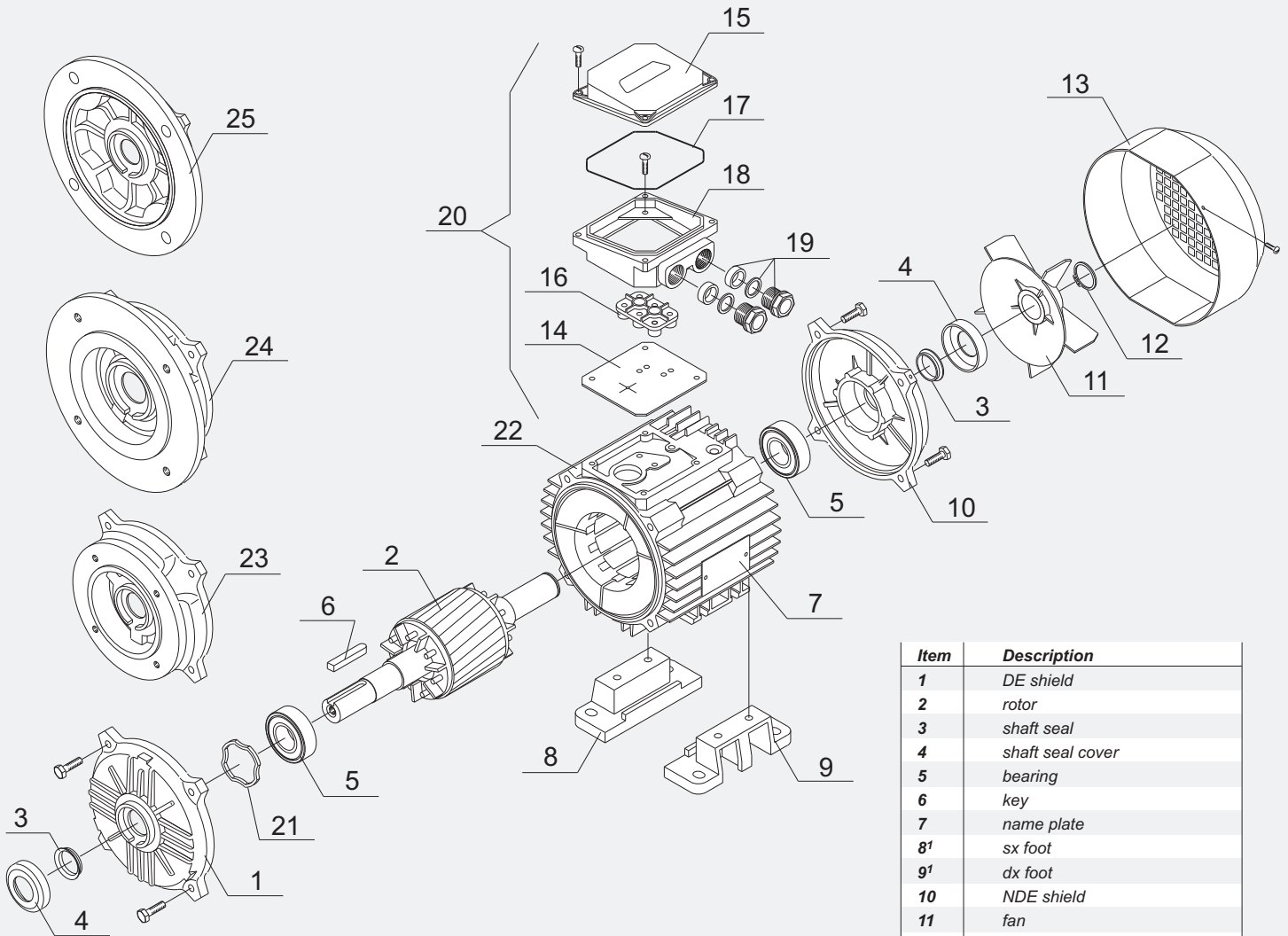

Item	Description
1	DE shield
2	rotor
3	shaft seal
4	shaft seal cover
5	bearing
6	key
7	name plate
8 ¹	sx foot
9 ¹	dx foot
10	NDE shield
11	fan
12	seeger ring
13	fan cover
14	rubber gasket
15	terminal box cover
16	terminal board
17	rubber gasket
18	terminal box
19	glands
20	terminal box complete
21	spring washer
22	stator
23 ²	flange B14/C2
24 ²	flange B14/C1
25	flange B5

DE - drive end
NDE - non drive end

1 - for frame size 132 feet can be screwed or integrated with the motor housing, for frame size 160 -180 feet are integrated with the motor housing.
2 - only for frame size 90 - 132.

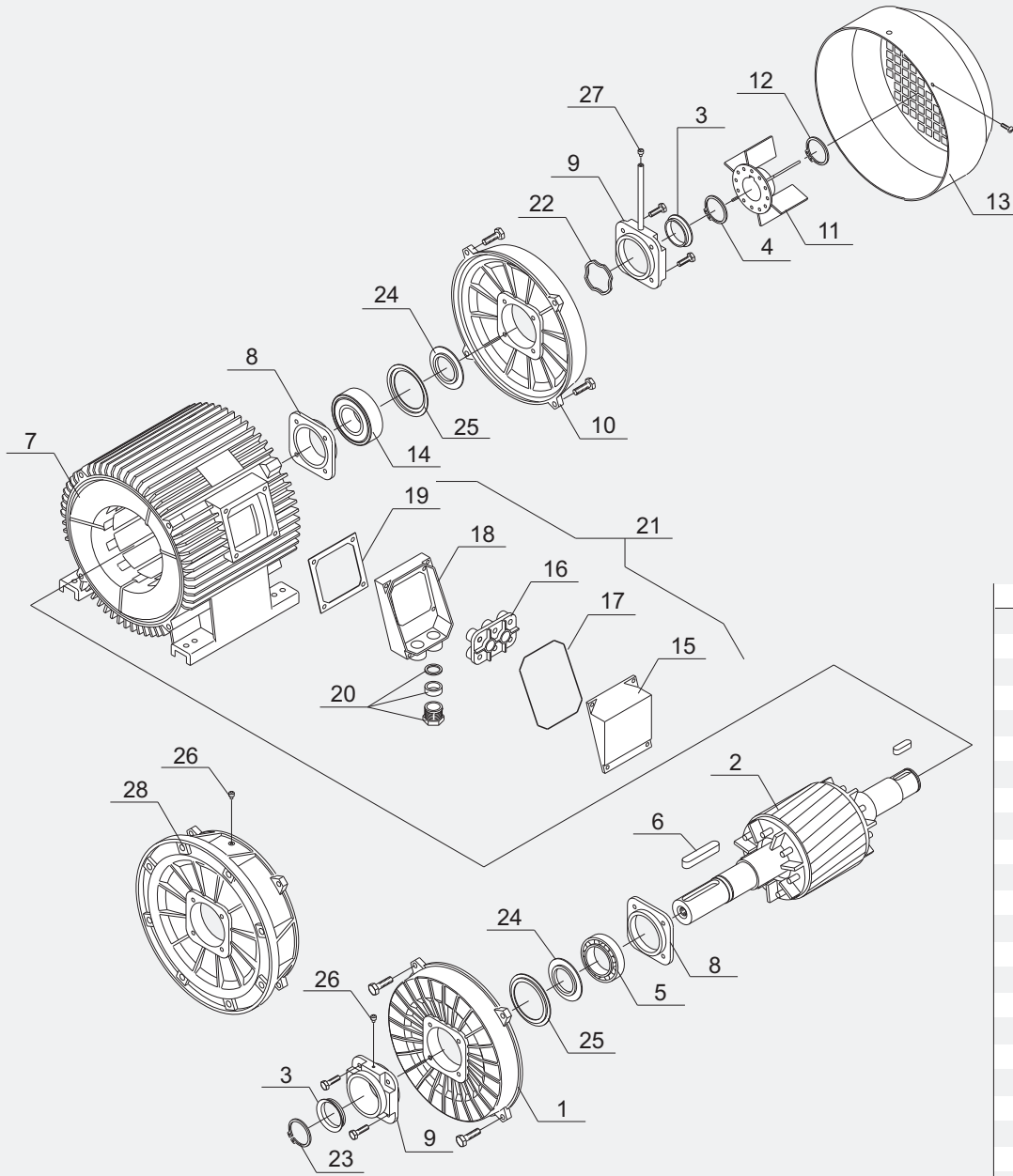

Item	Description
1	DE shield
2	rotor
3	shaft seal
4 ¹	seeger ring
5	DE bearing
6	key
7	stator with foot
8	internal bearing cap
9	external bearing cap
10	NDE shield
11	fan
12	seeger ring
13	fan cover
14	NDE bearing
15	terminal box cover
16	terminal board
17	rubber gasket
18	terminal box
19	rubber gasket
20	glands
21	terminal box complete
22	spring washer
23	seeger ring
24 ²	grease shield
25 ²	bearing internal ring
26	DE lubricator
27	NDE lubricator
28	flange B5

¹ - only for frame size 200,225,355

² - only for frame size 280-315

DE - drive end
NDE - non drive end

PRODUCTION PROGRAM

OUTPUT RANGE [kW]

GENERAL PURPOSE 3-PHASE INDUCTION MOTORS	0,04 - 1400
GENERAL PURPOSE 1-PHASE INDUCTION MOTORS	0,04 - 2,2
HIGH VOLTAGE INDUCTION MOTORS	
Totally enclosed motors IP55	160 - 4000
Totally enclosed motors for power engineering IP55	200 - 2000
Open drip proof motors IP23	200 - 1250
MOTORS WITH ENLARGED RATED OUTPUT	0,12 - 200
MOTORS WITH FOREIGN COOLING	
Motors with foreign cooling IP54 (IP55)	0,09 - 1400
Motors with foreign cooling IP20	0,09 - 2,2
3-PHASE INDUCTION MOTORS FOR PUMPS	
Standard motors for pumps	0,37 - 90
Explosion-proof motors for pumps	11 - 45
Explosion-proof marine motors for pumps	10 - 50
MOTORS TO BE BUILT-IN	
1-phase motors to be built-in	0,06 - 1,5
3-phase motors to be built-in	0,09 - 160
BRAKE MOTORS	
Brake motors (with DC brake)	0,09 - 160
Brake motors (with AC brake)	3 - 11
EXPLOSION-PROOF MOTORS	
Increased safety motors	0,09 - 22
Flame-proof motors	11 - 250
Flame-proof marine motors	10 - 99
Special purpose flame-proof motors for mining	4,5 - 170
Special purpose flame-proof motors for chemical industry	5,5 - 45
Special purpose flame-proof marine motors	10 - 50
High voltage flame-proof motors	200 - 1400
MOTORS FOR AXIAL-FLOW FANS	
1-phase motors for axial-flow fans	0,18 - 0,75
3-phase motors for axial-flow fans	0,2 - 1,1
3-phase motors for axial-flow mining fans	11 - 55
3-phase explosion-proof motors for air duct axial-flow fans	7,5 - 90
3-phase marine motors for axial-flow fans	0,75 - 25,3
3-phase explosion-proof marine motors for axial-flow fans	10 - 18,5
3-phase multi-speed motors for axial-flow fans	0,18 - 0,75
3-phase multi-speed motors for air duct axial-flow fans	10 - 40

PRODUCTION PROGRAM

OUTPUT RANGE [kW]

MULTI-SPEED MOTORS		
General purpose 2-speed motors		0,07 - 250
General purpose multi-speed motors		0,12 - 60
MARINE MOTORS		
General purpose marine motors		0,06 - 350
Marine motors for pumps		22 - 99
Marine motors for axial-flow fans		0,75 - 25
Marine motors for boat davits		9 - 30
Marine motors for tubular rudders		200 - 2000
General purpose explosion-proof marine motors		3,5 - 99
Explosion-proof marine motors for pumps		10 - 50
Explosion-proof marine motors for axial-flow fans		10 - 18,5
WOUND ROTOR INDUCTION MOTORS		
Totally enclosed (IP 54, 55) wound rotor induction motors		18,5 - 315
Open drip proof (IP 23) wound rotor induction motors		55 - 315
CRANE MOTORS		
Squirrel cage crane motors		2,2 - 15
Wound rotor crane motors		0,8 - 185
Two-speed crane motors with brake		0,28 - 13
SPECIAL PURPOSE INDUCTION MOTORS		
Motors with increased slip		5,5 - 22
Roller table motors for iron and steel industry		1,1 - 7,5
1-phase motors with shaft height 65 mm		0,75 - 2,0
3-phase motors with shaft height 65 mm		0,75 - 2,0
HIGH EFFICIENCY SEE MOTORS		0,55 - 315
MOTORS ACCORDING TO NEMA AND CSA STANDARDS		0,8 - 500 [HP]
ACCESSORIES		
DC electromagnetic disc brakes	braking torque	4 - 800 [Nm]
AC electromagnetic disc brakes	braking torque	4 - 300 [Nm]
Powder brakes and clutches	torque	6 - 170 [Nm]
Thrustors	force of piston rod	500 - 3200 [N]

PRODUCTION PROGRAM

CANTONI
MOTOR



ISO 9001

CANTONI MOTOR S.A.
M. Grażyńskiego 22
43-300 Bielsko-Biała, Poland
tel.: +48 33 813 87 00
fax: +48 33 813 87 01
motor@cantonigroup.com
www.cantonimotor.com